



CONTENTS

LOCATIONS	02
MISSION STATEMENT	04
CHAPTERS	
A – ACRYLIC	06
B – BAG & COVER	08
D – CUBBY	10
E – DISPLAY STAND & TOP	12
F – DISPLAYER	14
G – GONDOLA & DIVIDER	18
H – GRIDWALL	22
I – HANGER	24
J – HANGRAIL, BRACKET, SHELVING, STANDARD & ETC.	26
L – MANNEQUIN & FORM	28
M – WIRE SHELVING SYSTEM	30
N – OTHER STORE DISPLAY	32
O – OTHER STORE SUPPLY	34
P – PEGBOARD FIXTURE	36
R – RACK	38
T – SHOWCASE, COUNTER, TABLE & MIRROR	42
U – SIGNHOLDER	44
V – SLATWALL	46
Y – WALL SYSTEM	48
Z – FACE-OUT & WATERFALL	50
CUSTOMER SERVICE	52
QUALITY CONTROL AND QUALITY ASSURANCE	53
CUSTOM DESIGN	54
MANUFACTURING AND WORKMANSHIP	56
WAREHOUSING & DISTRIBUTION	58
PAYMENT AND FINANCING	60

CONTACT US





● **Headquarter and Warehouse**

12930-12950 Alondra Boulevard,
Cerritos, CA 90703, U.S.A.
office: (562) 802-0888
toll free: (855) DBJ-DISP
fax: (562) 802-1111
salespf@displaysbyjack.com
www.displaysbyjack.com

● **Canada Western Territory
Mexico Western Territory
USA West Coast Region**

contact: Mike Iljin
office: (714) 882-0907
mikeiljin@displaysbyjack.com

● **USA Midwest Region**

contact: Chris Weaver
office: (714) 357-5705
chrisweaver@displaysbyjack.com

● **Mt Prospect, Illinois Office**

● **Georgia, Atlanta Office**

● **Canada Eastern Territory
USA East Coast Region**

contact: John Pasciucco
office: (203) 912-8347
johnp@displaysbyjack.com

MISSION STATEMENT

First and foremost, Displays by Jack is about people. Our employees, coupled with our customers are the heart and soul of the company. We strive to provide the best value, highest quality products, superior customer service, utmost respect and personal care.

You have a business to run.
but it should not consume most
this way. Life could be easier when



You dream about it.

We provide design service, fabrication, warehousing, s

Displays By Jack, has the global capabilities that allow us to provide our customers with endless opportunities. In collaboration with a network of world-wide partners, we are able to offer our customers a

Custom items will be priced according to quantity, material, finish and destination. Contact our factory representatives for quantity pricing and your custom design items.

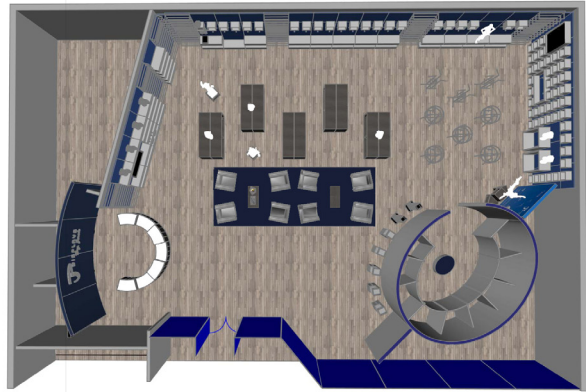
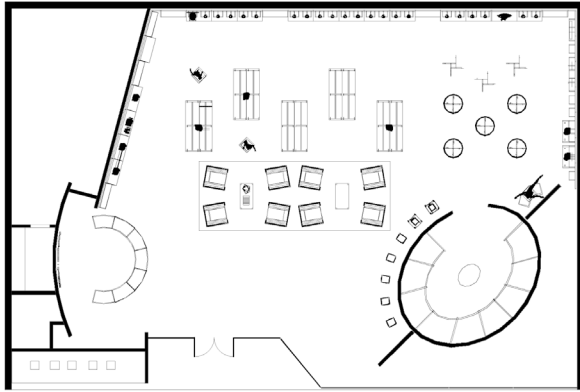

**Building stores is a big part of it
of your energy. It doesn't need to be
you partner up with**



, shipment and installation. So, you have more time to run your business.

large selection of design options and a wide array of material choices. Displays by Jack seeks to maximize our client's growth potential through the company's rich experience and global capabilities.

Please visit us at www.DisplaysByJack.com for more selections.

SHOE DISPLAYS & RISERS FOR COUNTERTOP



G-BENDS SET/3
1210

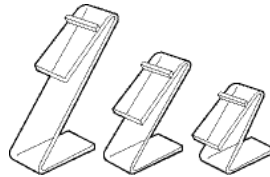

Z-BENDS SET/3
1205

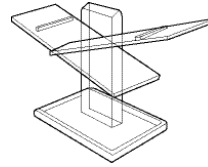

COUNTER DISPLAY
ACSD

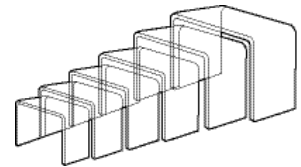

SHOE RISER SET/6: # 228-1212

CARD HOLDERS FOR COUNTERTOP

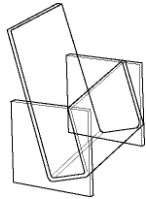

COUNTER TOP BROCHURE HOLDER
holds 4" x 9" brochures
228-1100

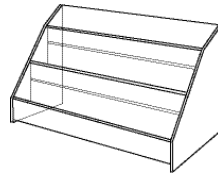

3 TIER RACK FOR GREETING CARDS & VIDEO CASSETTES
on countertop or wall mounted
226-1349

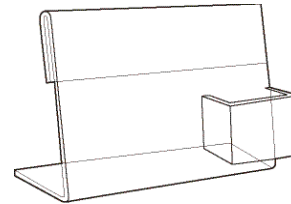

SIGN HOLDER WITH LITERATURE POCKET
holds 13"W x 11"H sign and dispenses 4"W x 9"H literature
AC-1086

JEWELRY TRAY

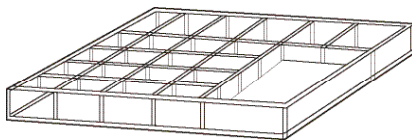

ACRYLIC JEWELRY TRAY
AC-2200

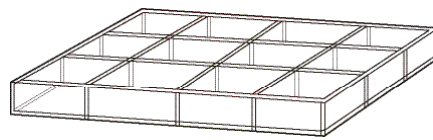

ACRYLIC JEWELRY TRAY WITH VELVET
AC-2201

EASEL

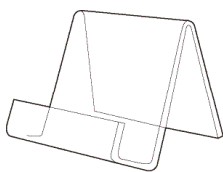

AC-1060, # AC-1062,
AC-1064, # AC-1066

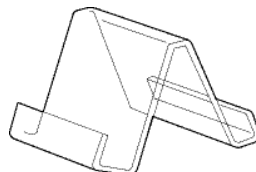

ACES

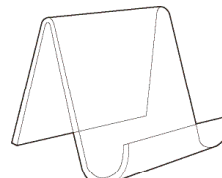

AC-1061

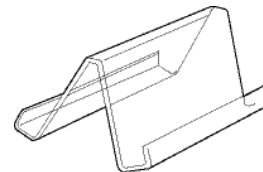

ACET

SIGN HOLDER COLLECTION

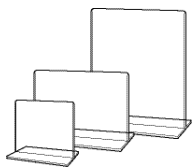

PG series

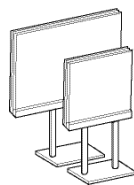

SAP series

GRIDWALL ACCESSORIES

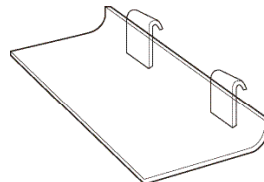

ACRYLIC SHELF
AC-3001

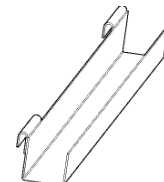

J-RACK SHELF
G2270



SLATWALL ACCESSORIES

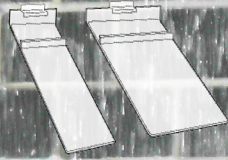

SHOE FACEOUTS
2084 & # 2086

Down Slant Displayer
For use where frontal and
top view is desired, Great
for shoe, telephone and
electronics display
ID821



LEFT SHOE
SHELF #2075 -1

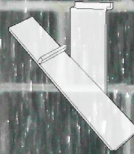

RIGHT SHOE
SHELF # 2073

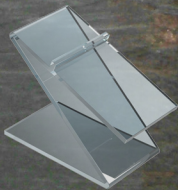
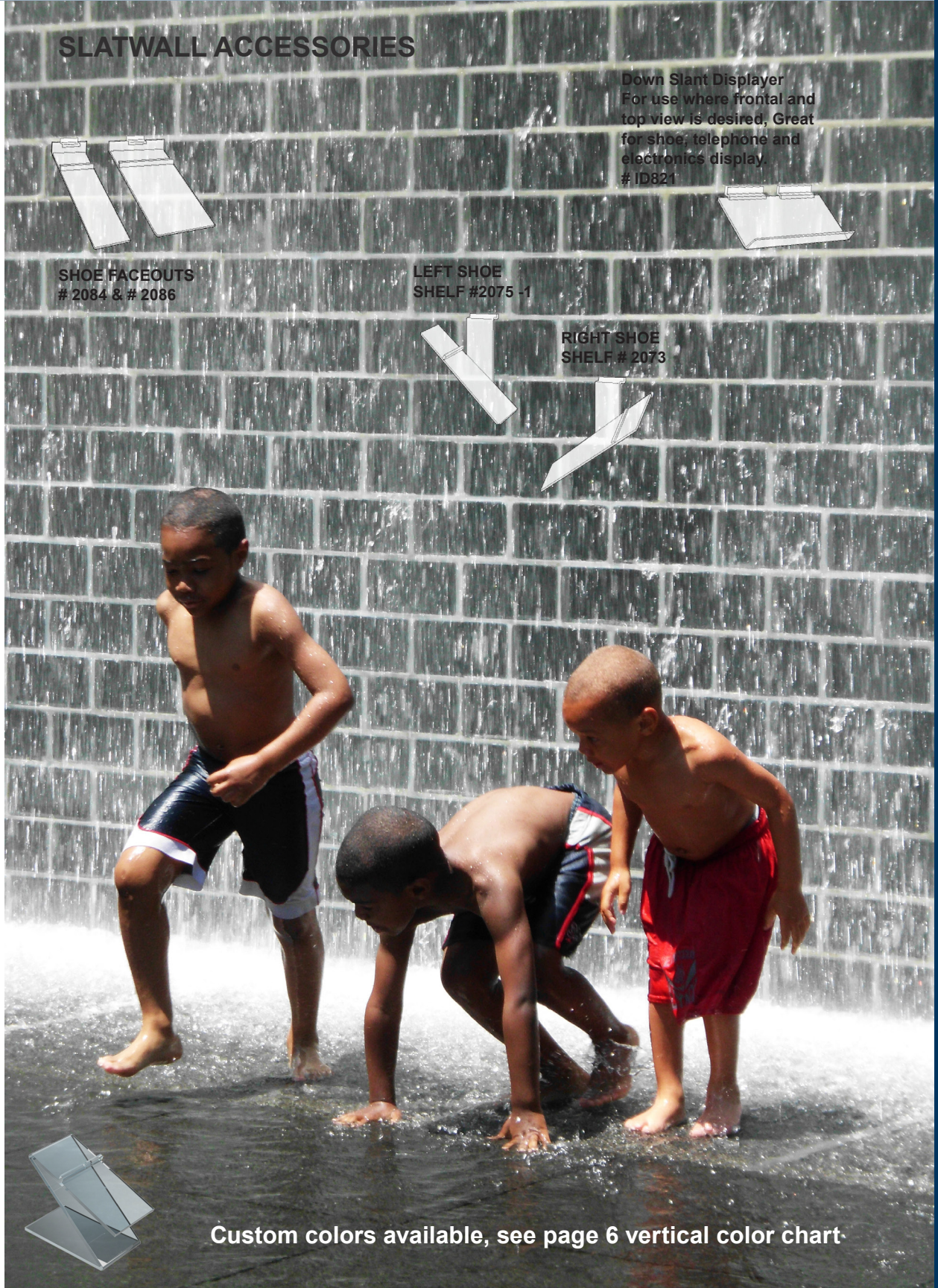

Custom colors available, see page 6 vertical color chart.

A ACRYLIC

B

BAG & COVER

CUSTOM FABRIC, PLASTIC AND PAPER BAGS

Custom printing is now available. Artworks are to be provided by the buyers. Our factory representatives can assist you on bag material and printing method selections. Also ask us about the variety of gift boxes and tissue papers you are looking for. DBJ commits to be your one stop shop for your retail solution. See a significant saving on your next orders.

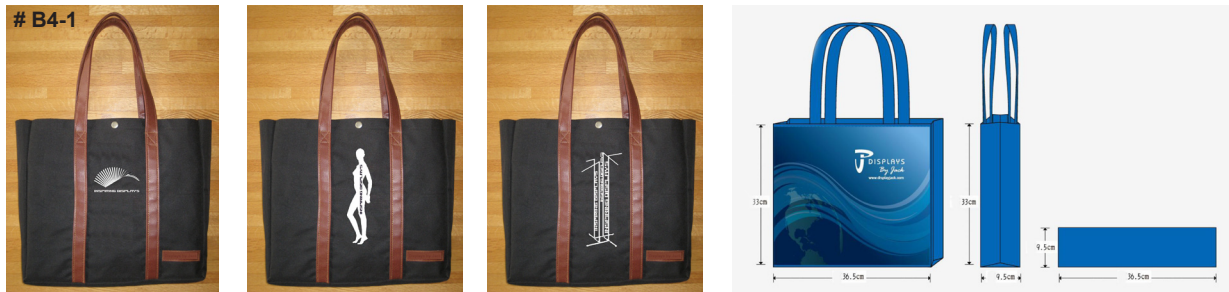

HIGH-DENSITY PLASTIC



PB series

Note: All 10 colors are yellow, red, white, hunter green, silver, powder blue, burgundy, royal blue, dusty rose and teal.

LOW-DENSITY PLASTIC



PBK series

Note: All 12 colors are white, teal, dusty rose, gray, burgundy, ivory, navy, black, royal blue, gold, dark green and red.

GARMENT BAG & COVER



STRAP-TOP BAG
Canvas Material
Size Navy Blue
38" long # BS38
48" long # BS48
57" long # BS57



SALESMAN'S BAG
Canvas Material
Size Navy Blue Black
38" long # BG38 # BG38-B
48" long # BG48 # BG48-B
57" long # BG57 # BG57-B
66" long # BG66 # BG66-B
72" long # BG72 # BG72-B

Nylon Material
Size Navy Blue
38" long # BG38N
48" long # BG48N
57" long # BG57N
66" long # BG66N
72" long # BG72N



LOCKABLE GARMENT RACK COVER
Nylon Material, Navy Blue
60" L X 50" W
RCA100



BAGS
BOXES
FABRIC
PLASTIC
PAPER



B BAG & COVER

Please visit us at www.DisplaysByJack.com for more selections.

D

CUBBY

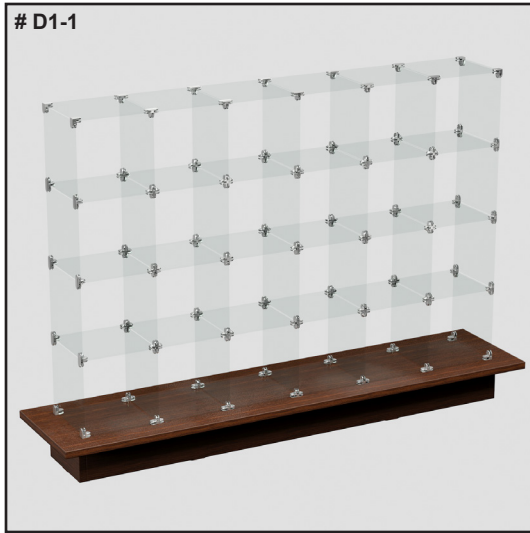

(58) # GC1010T
 (8) # CON2; (32) # CON3; (30) # CON4
 (1) # T6-5C-CH 70"X16"X6" laminated melamine base

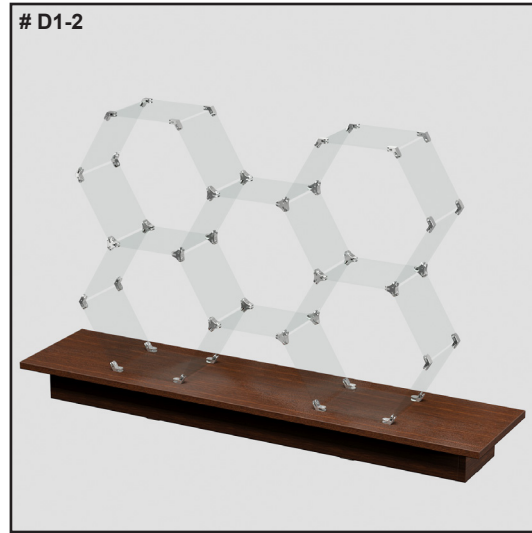

(24) # GC1010T; (24) # CON2-N; (16) # CON3-N
 (1) # T6-5C-CH 70"X16"X6" laminated melamine base

TEMPERED GLASS PANELS

1/4" thick, with pencil polished edges.

Item #	Size
# GS1024T	10" x 24"
# GS1036T	10" x 36"
# GS1048T	10" x 48"
# GS1224T	12" x 24"
# GS1236T	12" x 36"
# GS1248T	12" x 48"
# GS1424T	14" x 24"
# GS1436T	14" x 36"
# GS1448T	14" x 48"

3/16" thick, with pencil polished edges.

Item #	Size
# GC1010T	10" x 10"
# GC1012T	10" x 12"
# GC1014T	10" x 14"
# GC1016T	10" x 16"
# GC1024T	10" x 24"
# GC1048T	10" x 48"
# GC1212T	12" x 12"
# GC1214T	12" x 14"
# GC1216T	12" x 16"
# GC1224T	12" x 24"
# GC1248T	12" x 48"
# GC1414T	14" x 14"
# GC1416T	14" x 16"
# GC1424T	14" x 24"
# GC1448T	14" x 48"

QUARTER ROUND GLASS PANELS

3/16" thick, with pencil polished edges.

Item #	Size
# GQR10T	10" x 10"
# GQR12T	12" x 12"
# GQR14T	14" x 14"
# GQR16T	16" x 16"

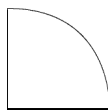

CONNECTORS

- Durable zinc die casting connectors with reinforced nylon screw
- Chrome plated and brass plated.
- Fits up to 3/16" glass
- for tempered glass only



CON2
2 Way 90°



CON3
3 Way 90°

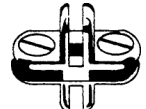

CON4
4 Way 90°



CON2-N
2 Way 120°



CON3-N
3 Way 120°



CON2-HD
2 Way H/D Hinge



CON2-H
2 Way Hasp,
w/out pin
CON2-H1
2 Way Hinge,
With pin



MS3
3 Way Adjustable



MS4
4 Way adjustable

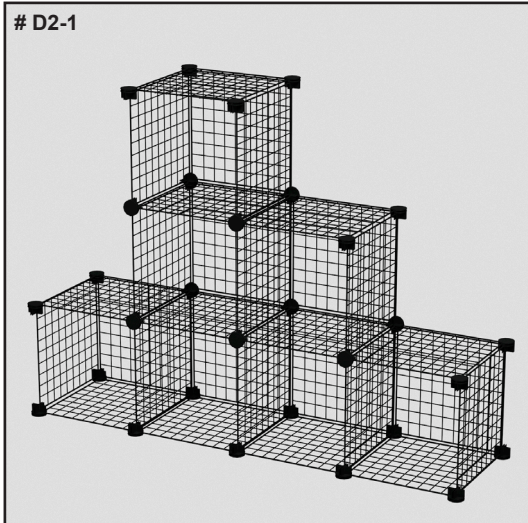

(28) # GS14B;
(30) # GSC-B

PLASTIC COATED GRID PANELS (1-1/2" GRID)

White	Black	Red	Sizes
# GS14W	# GS14B	# GS14R	14" x 14"
# GS16W	# GS16B	# GS16R	10" x 16"
# GS10W	# GS10B	# GS10R	10" x 10"

8-WAY PLASTIC CONNECTORS



GSC-B Black
GSC-W White
GSC-R Red

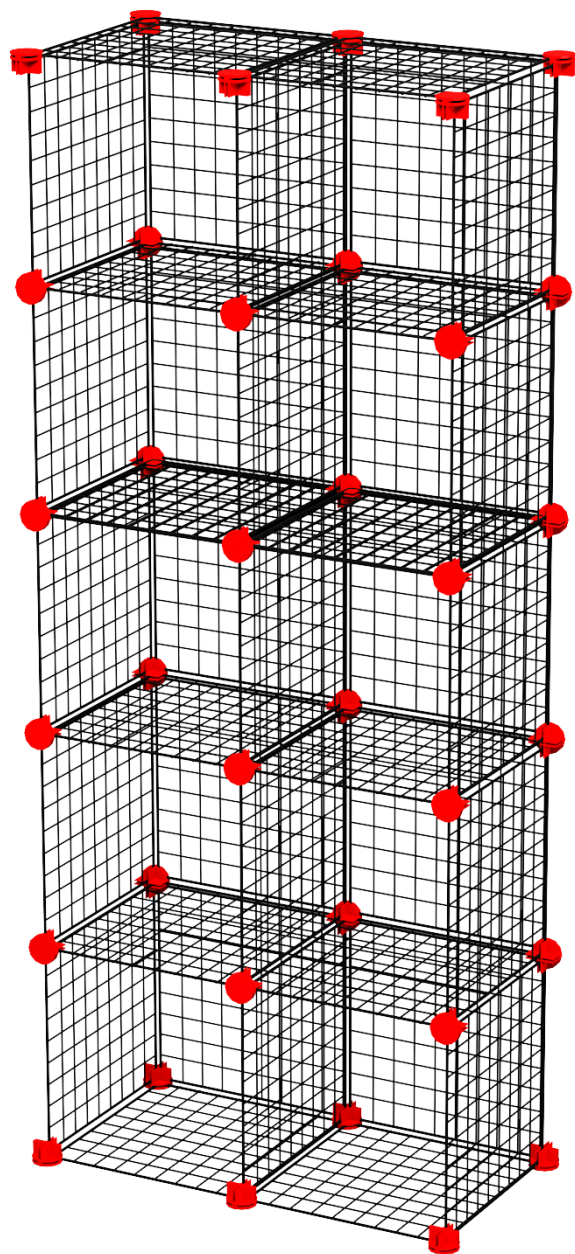

D2-2
(37) # GS14B;
(36) # GSC-R

E

DISPLAY STAND AND TOP

WATER FALL DISPLAYER



PB8-1825
Tent style, 10 balls,
8" base
5/8" x 18/36" extension



PB8-1820
Single slant, 10 balls,
8" base
5/8" x 18/36" extension

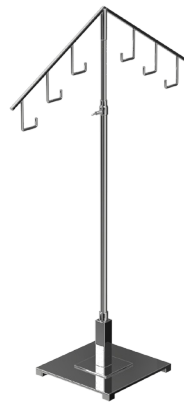

PB8-1826
Tent style, 6 hooks,
8" base
5/8" x 18/36" extension



PB8-1821
Single slant, 6 hooks,
8" base
5/8" x 18/36" extension

MIRROR



PB6-E4-1
Oval double face,
with tilt fitting,
10" x 14", 6" base

REVOLVING DISPLAYER

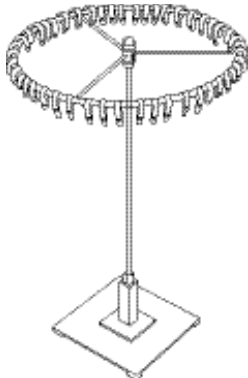

PB8-3010
Scarf stand
8" base
5/8" x 18/36" extension
14" diameter, ball bearing
fitting- not including 100
plastic clips.



PB10-3012
Tie stand
10" base
5/8" x 31" upright,
17" diameter, ball
bearing fitting, 12
spokes for hook
riders.

BASE OPTIONS



TRUMPET BASE
TRB5 - 5" Base
TRB6 - 6" Base
TRB8 - 8" Base
TRB10-10" Base

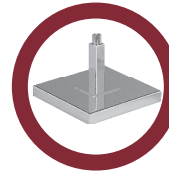

SQUARE BASE
SB5 - 5" Base
SB6 - 6" Base
SB8 - 8" Base
SB10 - 10" Base

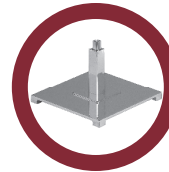

PARSONS BASE
PB5 - 5" Base
PB6 - 6" Base
PB8 - 8" Base
PB10 - 10" Base

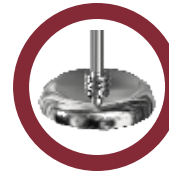

ROUND BASE
MB4 - 4" Bases
MB5 - 5" Bases
MB6 - 6" Bases
MB8 - 8" Bases
MB10-10" Bases



BLOUSE DISPLAYER



PB6-E4-3
Adjustable gooseneck
with waist cincher,
6" base
5/8" x 18/36" extension,
16" hanger.



PB8-1816
Adjustable gooseneck
with 11" skirt or slack
arm, 8" base
5/8" x 18/36" extension,
16" hanger.

OTHER DISPLAYER AND FITTINGS

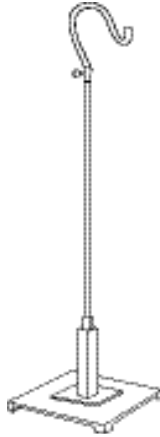

PB6-E4-2
Hook Stand
6" base,
5/8" x 18/36"
extension

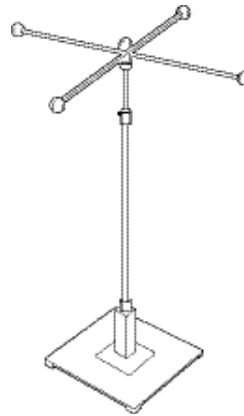

PB8-1834
Adjustable Revolving
rope stand, 8" base
5/8" x 18/36" extension
1 1/2" diameter, 4 arms
ball bearing fitting.



E1-11
Dress Top-17" wide
3/8" wire - 3/8" fitting



HT15 -Tee Top-15" wide
HT18 -Tee Top-18" wide
HT21 -Tee Top-21" wide
3/8" wire - 3/8" fitting



RDT3 -3 Ring Drapery Top
3/8" fitting

ADJUSTABLE AND NON-ADJUSTABLE STAND OPTIONS

4" BASE

- # 409 - 9" to 18" adjustable stand
- # 412 - 12" to 24" adjustable stand
- # 415 - 15" to 30" adjustable stand
- # 418 - 18" to 36" adjustable stand

5" BASE

- # 509 - 9" to 18" adjustable stand
- # 512 - 12" to 24" adjustable stand
- # 515 - 15" to 30" adjustable stand
- # 518 - 18" to 36" adjustable stand

Above stands have 1/4" diameter inner rod with 1/4-20 thread and 3/8" diameter outer tube.

6" BASE

- # 618 - 18" to 36" adjustable stand
- # 624 - 24" to 48" adjustable stand
- # 625 - 5/8" x 24" (not adjustable)

8" BASE

- # 818 - 18" to 36" adjustable stand
- # 824 - 24" to 48" adjustable stand
- # 830 - 5/8" x 30" (not adjustable)
- # 836 - 36" to 72" adjustable stand

Above adjustable stands have 3/8" diameter adjustable inner tube with 3/8-27 thread and 5/8" diameter outer tube with 5/8-27 thread.

10" BASE

- # 1036 - 7/8" X 36" (not adjustable)

UPRIGHTS ONLY

- # E1-1 - 3/8" x 9" x 18" (adjustable)
- # E1-2 - 3/8" x 12" x 24" (adjustable)
- # E1-3 - 3/8" x 15" x 30" (adjustable)
- # E1-4 - 3/8" x 18" x 36" (adjustable)
- # E1-5 - 5/8" x 18" x 36" (adjustable)
- # E1-6 - 5/8" x 24" x 48" (adjustable)
- # E1-7 - 5/8" x 36" x 72" (adjustable)
- # E1-8 - 5/8" x 24" (not adjustable)
- # E1-9 - 5/8" x 30" (not adjustable)
- # E1-10 - 7/8" x 36" (not adjustable)



F

DISPLAYER

EYEWEAR FLOOR DISPLAY FIXTURE

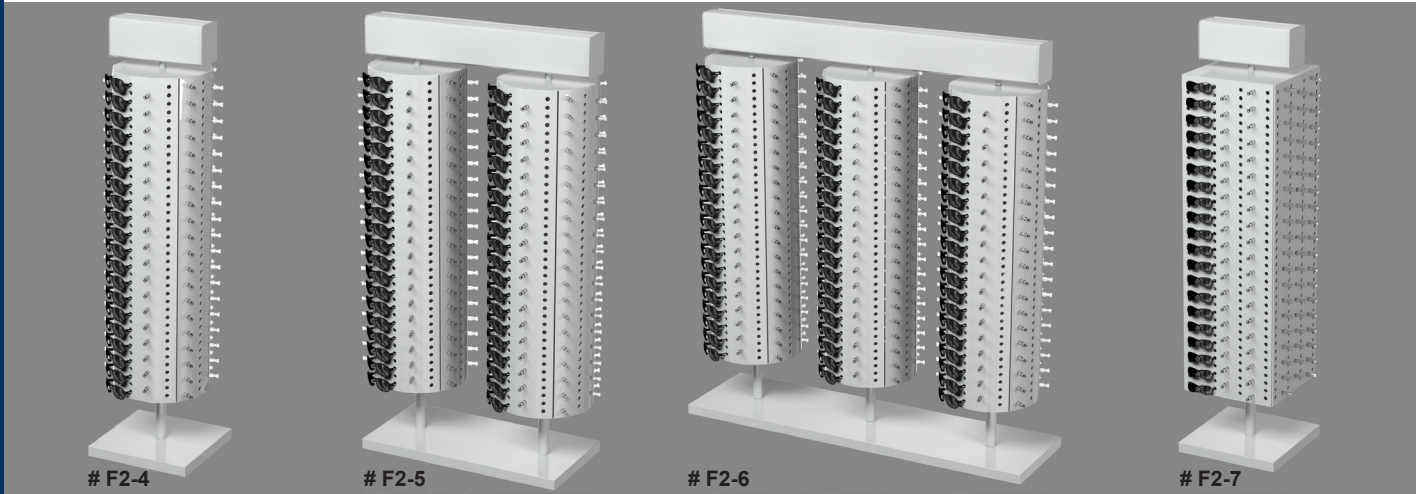

Above eyewear floor display fixtures are white powder coated on the top signages, revolving posts, perforated cylinder bodies, and fixture base (similar to Q10) with chrome rods. Add-on mirrors are optional. Custom colors and design alternations are available.



- (2) Metal 24"X48"X8" Display Platform
- (8) Custom Green Leave Eyeware Collection - Post

- (8) Concealed Wall Steel T - Standard B - Line #B31S-10B
- (8) Crossbar Brackets Left and Right # 3946-9 and # 3947-9
- (8) Crossbar 3/16" X1" # 3700-24
- (8) Custom Green Leave Eyeware Collection - Wallhung Unit
- (3) Custom Green Leave Eyeware Collection - Free Standing Unit



MODULAR OPTICAL DISPLAY FURNITURE AND FIXTURES



ACRYLIC DISPLAY PANEL

- (8) 48"X48" Acrylic Display Panel with Wall Mounted Hook (Modification of #WH6)
- (10) 8"X22" Mirror
- (10) Custom Green Leaf Eyeware Collection - Countertop Unit 8"X8"X46"
- (8) Custom Cabinet - Free Standing Unit with two Drawers 48"X18"X18" on 4" wheels
- (10) Custom Cabinet Collection - Free Standing Unit 10"X10"X36"

F DISPLAYER

F

DISPLAYER



DX-107



DX-108

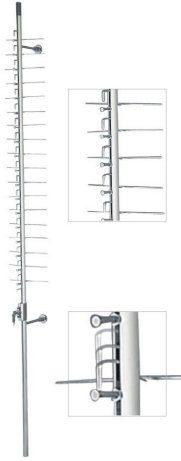

DX-109A



DX-128



DX-129



DX-132



DX-121B



DX-122



DX-123



DX-126



DX-127

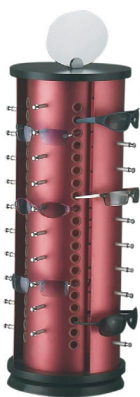

DX-203P

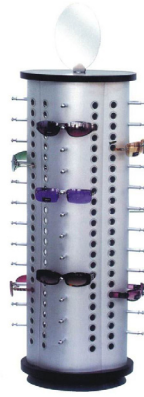

DX-204



DX-522

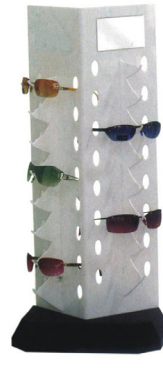

DX-523



DX-701



DX-702



DX-110B



DX-110C



DX-111



DX-118



DX-112

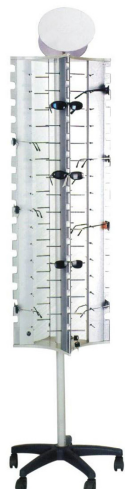

DX-405A



DX-405B



DX-406

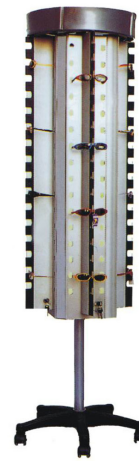

DX-403



DX-133

DX-506



DX-533



DX-534



DX-535



DX-539



DX-505



DX-503



DX-536



DX-537

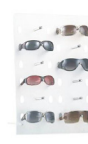

DX-538



DX-136

G

GONDOLA AND DIVIDER

Displays By Jack's new Universal Gondola Series (20 items at right) provide the ultimate flexibility for displaying merchandises and laying out new stores. The steel panel frame is designed to receive 24"X48" Gridwall, Slatwall (see Chapter V for panel color and groove treatment selections), Slatgrid and pegboard. The unit could be puzzled as one to five pieces assembling. Installation is as easy as 1-2-3. Add-on signages are optional.



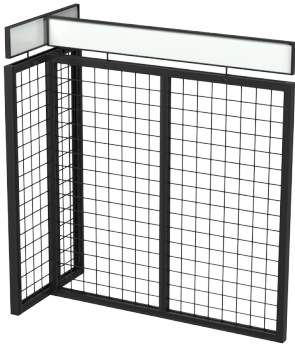

G1-2GW-B

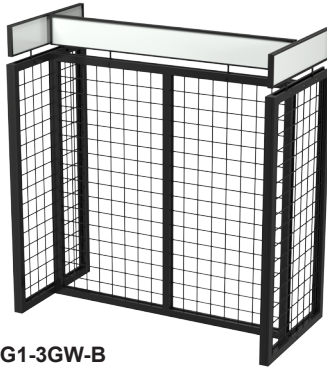

G1-3GW-B



G1-5GW-B



G1-2SW-B



G1-3SW-B



G1-5SW-B



G1-2SG-B



G1-3SG-B

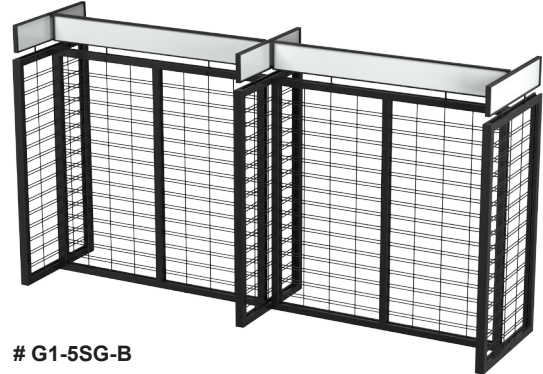

G1-5SG-B

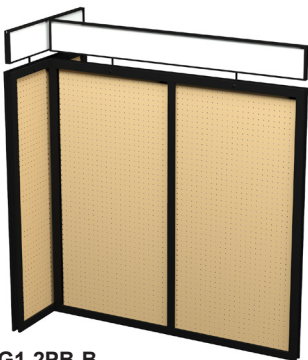

G1-2PB-B

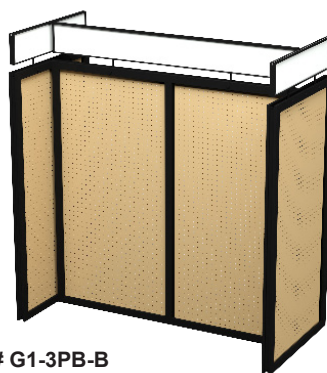

G1-3PB-B

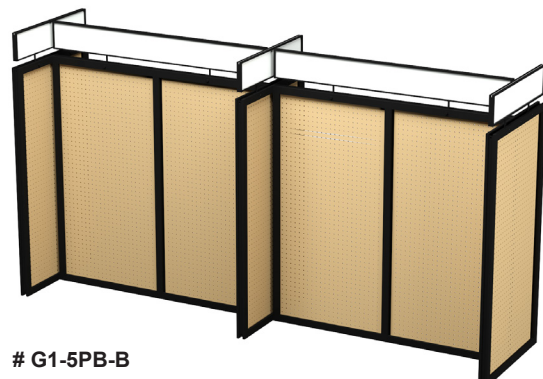

G1-5PB-B

G

GONDOLA AND DIVIDER

Displays By Jack's Gondola units are sold as kits and are designed to meet all your fixture needs. This system features a 1" on center slotting designed to exceed the load capacity of most retailer's needs. These units are virtually nut and bolt free and are easy to install.

A wide selection of component parts and accessories can be added to the Gondola Units, including shelves, racks wire fencing and back lit canopies, just to mention a few.

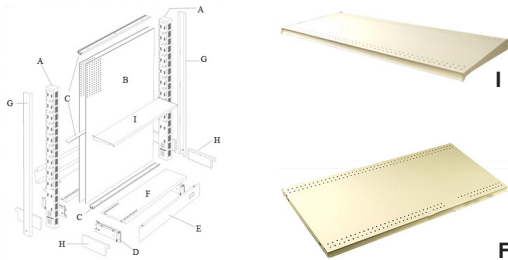

- A. UPRIGHTS: 48"~96"
- B. PEGBOARD BACK: 36"X48" ~ 48"X96"
- C. RAILS: 3'~4'
- D. BASE BRACKETS: 13"~22"
- E. FRONT KICK PLATE: 3'~4'
- F. BASE DECK: 13"X36"~22"X48"
- G. UPLIGHT POST COVER: 48"~96"
- H. BASE BRACKET SHOE COVER: 13"X22"
- I. SHELVING: 13"X36"~22"X48"
- J. STANDARD COLOR: ALMOND AND WHITE



Standard colors are almond and white; custom colors available with minimum order restriction.



CUSTOM EYEGLASSES RACK

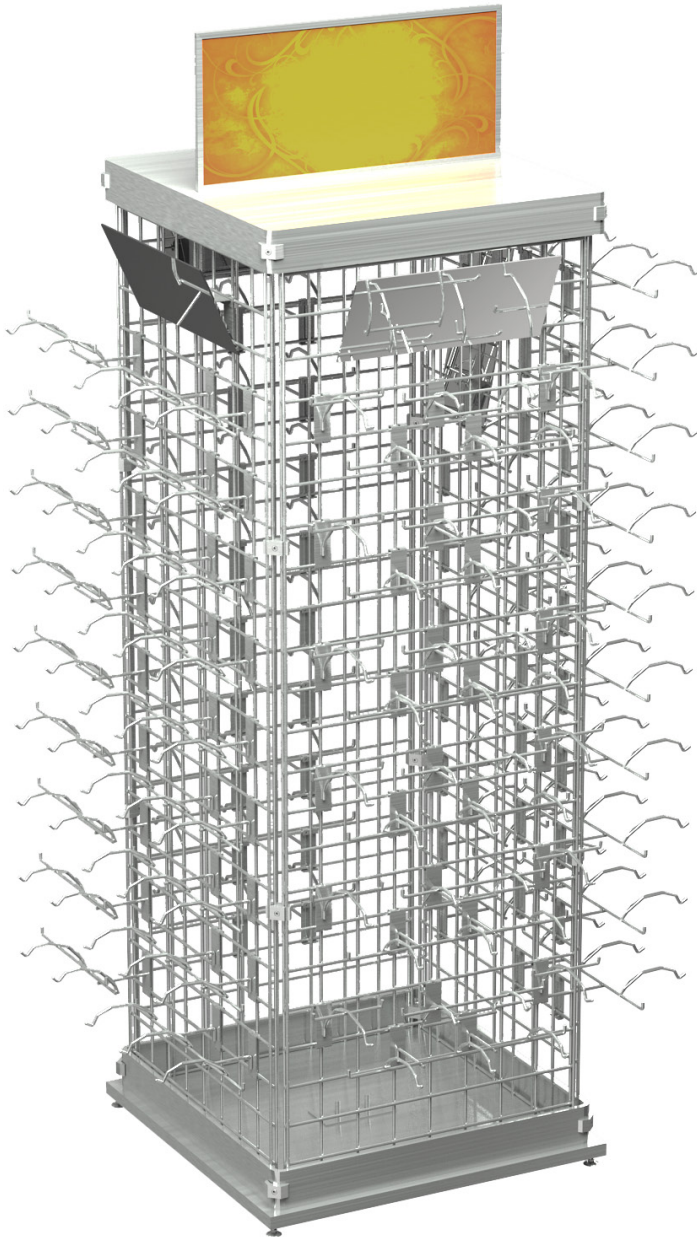

- # H1-1
 (1) # F2-1: 24"X24"X72" CUSTOM DISPLAY RACK
 (4) 18"X7" mirror
 (48) # GWEG
 (24) # GWEG-2 (modified)
 (24) # GWEG-3 (modified)

GRID WALL ACCESSORIES

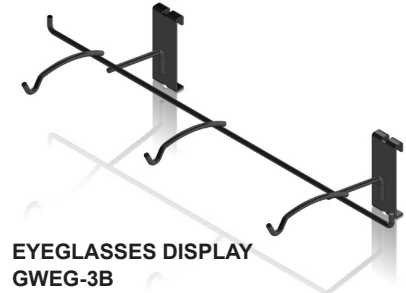
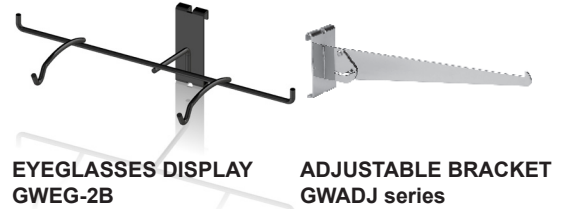

STANDARD ASSEMBLINGS

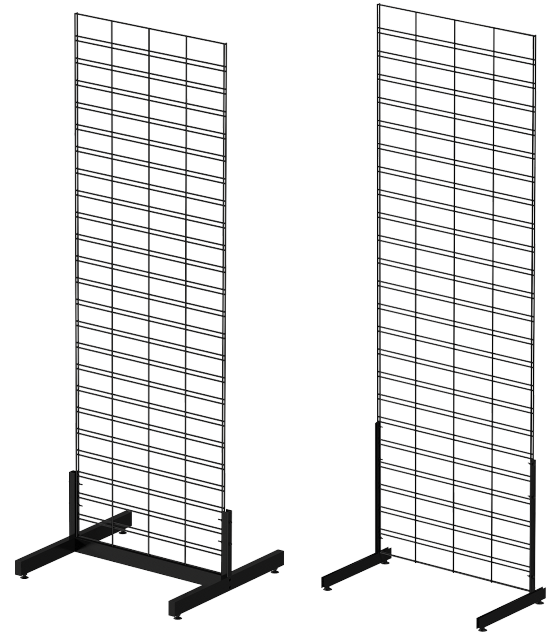

AS1631 with SG26

AS1614 with SG26



HANGRAIL BRACKET
GW12RT



HANGRAIL BRACKET
GWRT & GWRM

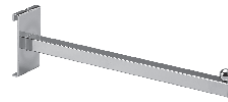

SQUARE TUBING FACEOUT
GW12

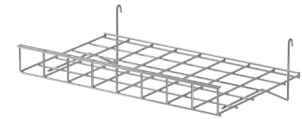

STRAIGHT SHELF WITH LIP
GW8 series



2' U-SHAPED HANGRAIL
H2-7



BALL HOLDER
GBB2-3 for 5" diameter



ROUND TUBING FACEOUT
GW11



LITERATURE TRAY
U2-1



STAIIGHT HANGRAIL
attaches between 2 panels
KHG682 & H2-5



BALL HOLDER
GWBH for 9-1/2" diameter
GWFH for 6" diameter



NARROW BASKET
GWB series



WESTERN HAT DISPLAY
GWHB

Note: Standard colors are black, white and chrome finish. Custom colors and finishes are available upon requests.

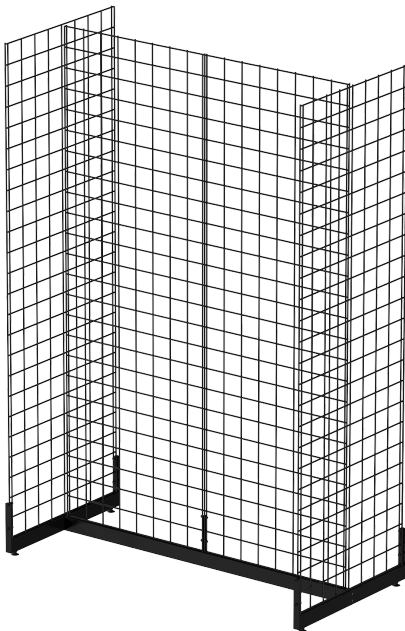

GW/G48 with GW26

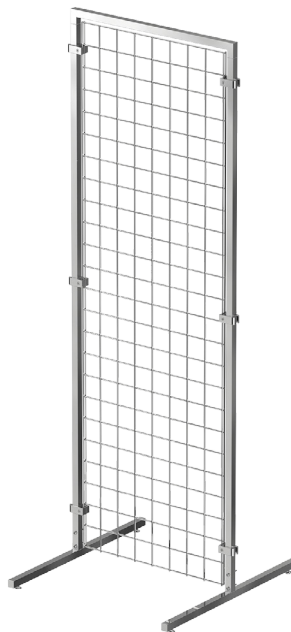

GL30, ST6, TOP24,
CGW5 & GW26

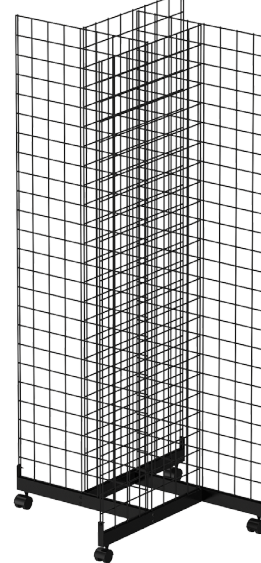

GW/4BA with GW26

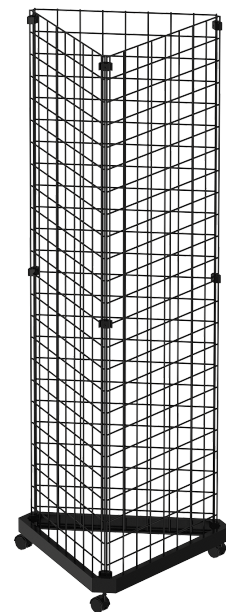

GW3TB with GW26

HANGER



STEEL HANGER

BDH-LH series

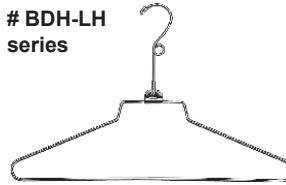

BDH-LH-T series

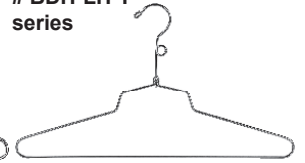

CH-LH series

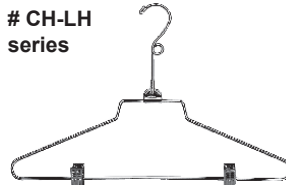

PR-15

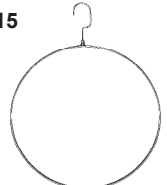

LING-16-LH

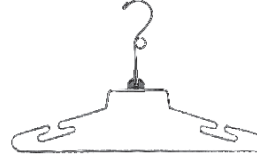

LING-16-LH-T

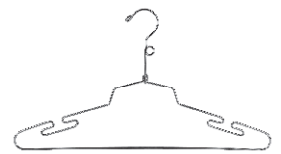

SH-12-LH

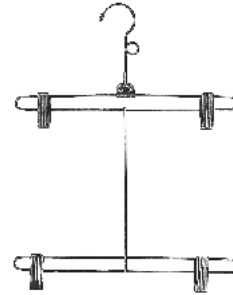

BBSH-12-LH

DA series

BAMBOO HANGER



FBH4 & # WBH4



FBH2 & # WBH2



FBH6 & # WBH6



BPH6



PLASTIC HANGER



17" LADIES DRESS HANGER
D60 and # D70 series



17" LADIES SUIT HANGER
D70B-PC, # D70C-MC and # D70W-MC

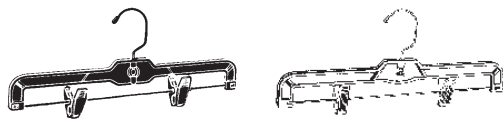

14" LADIES SKIRT HANGER
S80B-PC, # S80C-MC and # S80W-MC



10", 12" & 14" CHILD DRESS HANGER
D10, # D12 and # D14 series



12" & 14" CHILD SUIT HANGER
D12-PC, # D12-MC, # D14-PC and # D14-MC



12" CHILD SKIRT HANGER
S75B-PC, # S75C-MC and # S75W-MC



10" & 12" SNAP HANGER with zinc hook
I3-1-10 and # I3-1-12 series



10" & 12" SNAP HANGER with Plastic hook
I3-2-10 and # I3-2-12 series

Note: Plastic hangers have 3 styles - Black with black hook, Clear with zinc hook and White with zinc hook.

WOODEN HANGER



MC010



MC016



MC022



MC048



MK33



MK34



MP628



MP626



MP07



MP05

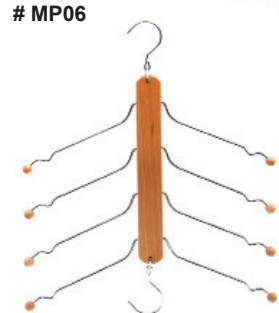

MP06

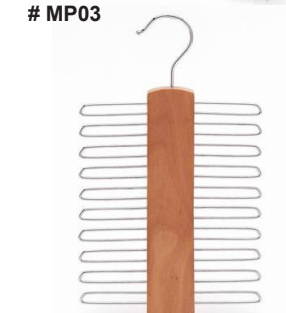

MP03



MP08-2

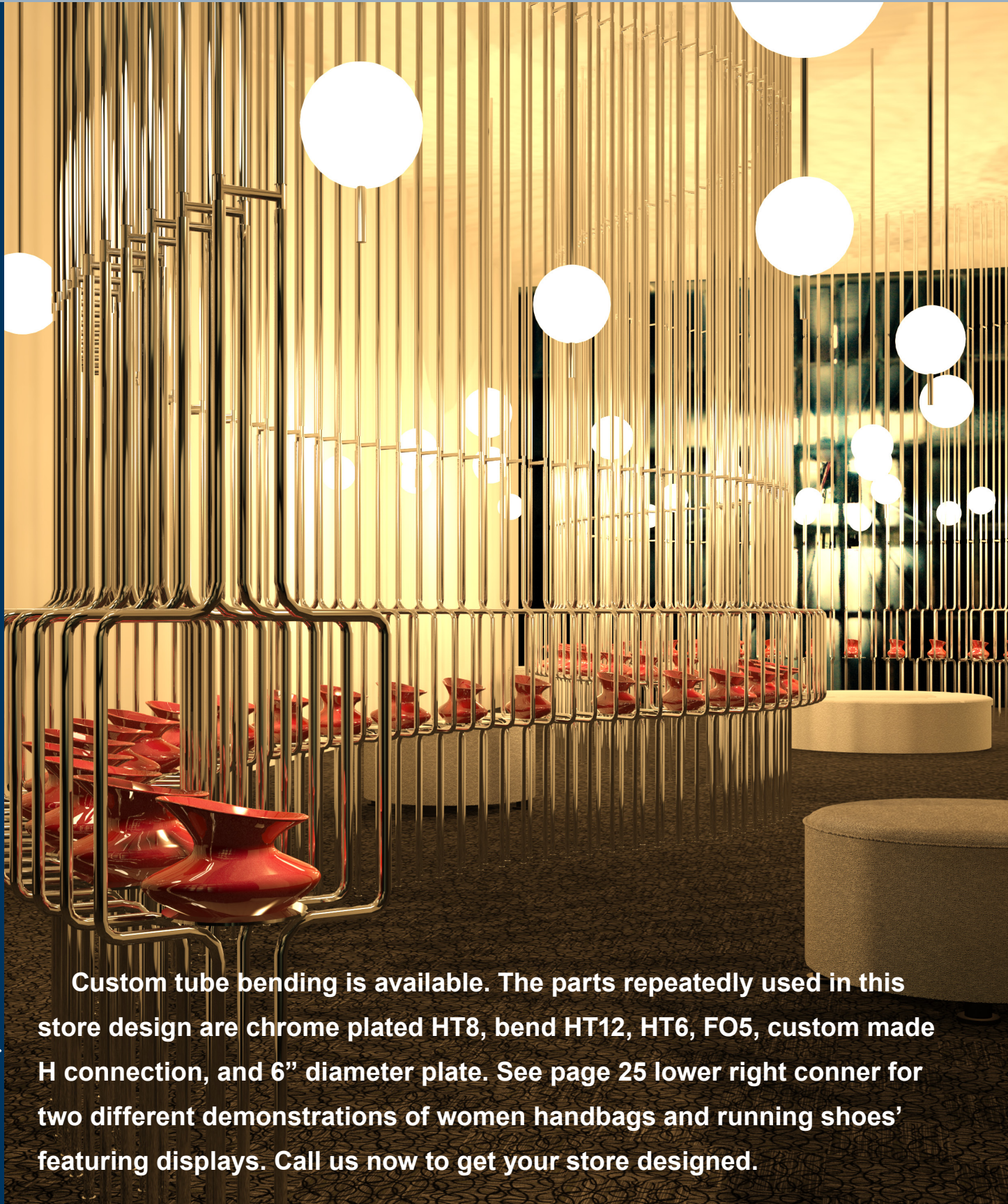

MP618

J**HANGRAIL, BRACKET, SHELVING, STANDARD & ETC.**

Custom tube bending is available. The parts repeatedly used in this store design are chrome plated HT8, bend HT12, HT6, FO5, custom made H connection, and 6" diameter plate. See page 25 lower right corner for two different demonstrations of women handbags and running shoes' featuring displays. Call us now to get your store designed.

STANDARD HANGRAILS



1" ROUND TUBING
17 Gauge - Chrome Plated
CT1 series



1-1/4" ROUND TUBING
17 Gauge - Chrome Plated
CT5 series



1" ROUND TUBING
14 Gauge - Chrome Plated
HT1 series



1-1/16" ROUND TUBING
14 Gauge - Chrome Plated
HT3 series



1-1/4" ROUND TUBING
14 Gauge - Chrome Plated
HT5 series



1" SQUARE TUBING
17 Gauge - Chrome Plated
ST series



1/2"X1-1/2" RECTANGULAR TUBING
17 Gauge - Chrome Plated
RT series

HANGRAIL ACCESSORIES



FU1
for 1" round tubing



FU5
for 1-1/4" round tubing



FO5
for 1-1/4" round tubing



FO1
for 1" round tubing

SHELF BRACKET



ADJUSTABLE - BWE series



FOR WOOD SHELVES
BWSC, BWSL & BWSR series



WEDGE TYPE - 4010 series



SCREW TIGHTENING - 120 series



FOR GLASS SHELVES
6266 series

SHELVES

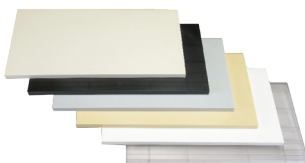

BULLNOSE INJECTION MOLDED SHELVES WITH OPEN BOTTOM



WOOD GRAIN BULLNOSE INJECTION MOLDED SHELVES WITH OPEN BOTTOM



MELAMINE WOOD SHELVES



FIBERGLASS MANNEQUIN - ABSTRACT COLLECTION

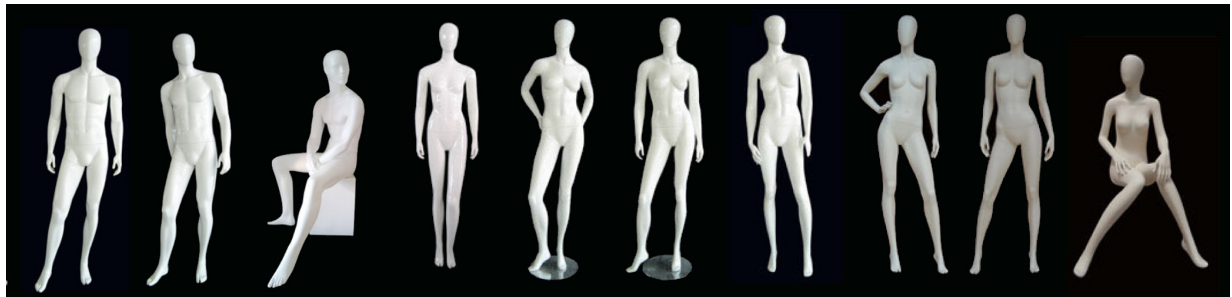

CA-M05 # CA-M06 # CA-M12 # CA-F01 # CA-F06 # CA-F07 # CA-F08 # CA-F12 # CA-F13 # CA-F14

WIRE MANNEQUIN COLLECTION

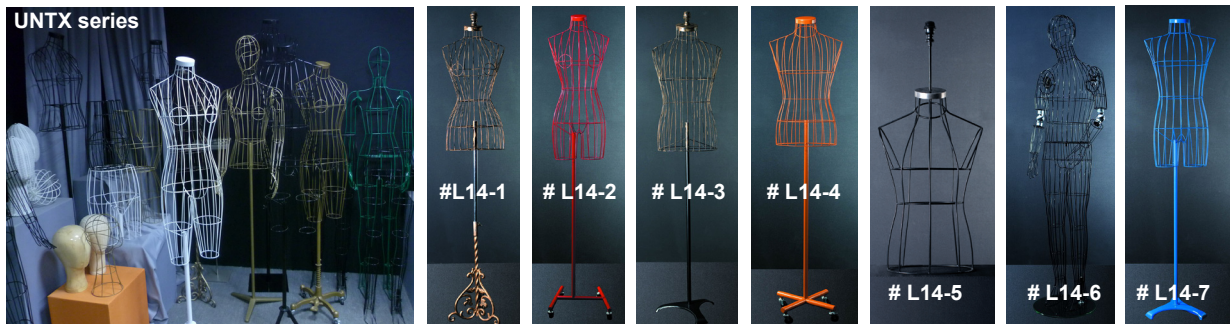

CUSTOMIZED TORSO FORM



L7-1 # L7-2 # L7-3

CHILDRED COLLECTION

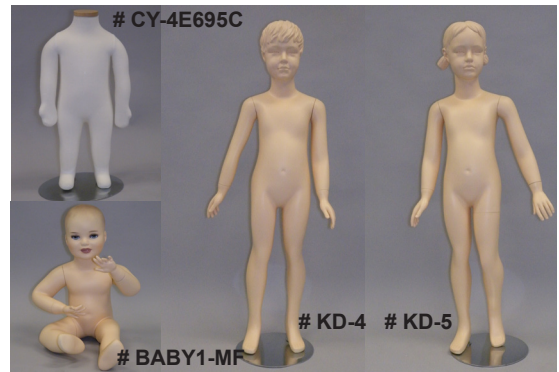

CY-4E695C
BABY1-MF
KD-4 # KD-5

WATER TRANSFER PATTERN



L13-1 # L13-2 # L13-3

PLASTIC MANNEQUIN & WIGS



T-20B # T-21 # T-25B # T-13



We use high quality and high density fiberglass - 20% fiberglass plus 80% resin. Finish with eco-friendly, non-benzene PU paint, which can be customized per your pantone color code. Matte and glossy finishes are optional. We also provide water-transfer pattern and chrome plated finishes. Our metal accessories are easy for assembling and stable. The metal base is 390mm diameter by 3mm thickness. Each whole body mannequin with calf/sole insert fitting. Last, we use high quality PVC hands that won't come out oil sludge after long usage in hot weather. Packing with EPE packaging and load in dual-covered cartons. That absorbs some impact and prevents damage during delivery. Customized mannequins are welcomed. Low mold charge, and high valued customized work. We can sculpture the mold per your design or magazine photos, any range, pose, finish, make-up, and with or without molded hair or wigs. Generally a prototype can be done in 2 weeks.

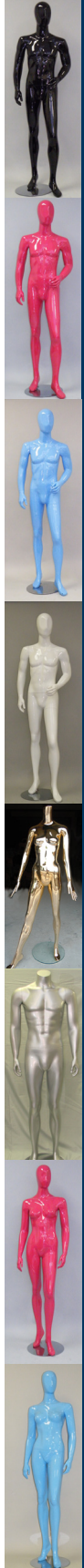

L MANNEQUIN & FORM



Global Shop 2011 Displays By Jack's exhibition booth featured wire shelving system with Wood grain laminated melamine door panels

MEDIUM WEIGHT WIRE SHELVES

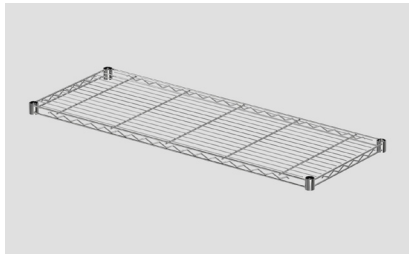

HEAVY WEIGHT WIRE SHELVES

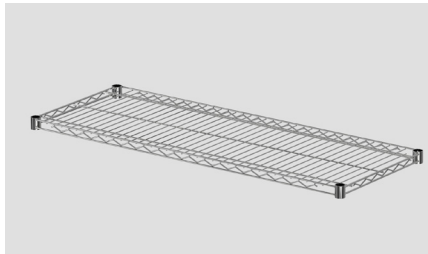

EXTRA HEAVY WEIGHT WIRE SHELVES

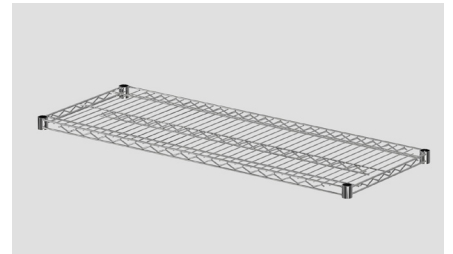

WIRE SHELVING SYSTEM ACCESSORIES

PLASTIC LABEL HOLDER # OM06	WALL MOUNT CLAMP # OM13	4" SIDE & BACK LEDGES #OM21	TOOL HOLDER # OM15	SHELF CONNECTOR # OM08	FOOT PLATE # OM10
UNDERSHELF BASKET # OM22	PULL-OUT SHELVING # OM32	RETAINS FRAME # OM23	HANGER RAILS # OM 24		
SNAP-ON HOOKS (SMALL) # OM16	SNAP-ON HOOKS (LARGE) # OM17	HOOK # OM18	LIGHT TYPE CANTILEVER SHELF # OM26L	HEAVY TYPE CANTILEVER SHELF # OM26H	



**MEDIUM DUTY 4 WIRE
SHELVING UNIT**
18"D x 36"W x 72"H
M1836-4-72B



**HEAVY DUTY 5 WIRE
SHELVING UNIT**
18"D x 36"W x 72"H
H1836-5-72C



**HEAVY DUTY 4 WIRE
SHELVING UNIT**
18"D x 48"W x 72"H
H1848-4-72C



**HEAVY DUTY 5 WIRE
SHELVING UNIT**
18"D x 48"W x 72"H
H1848-5-72C

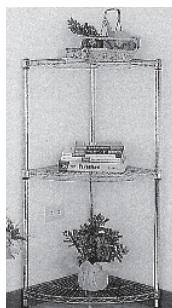

SPACIOUS UNIT



OM25



OM25S



KITCHEN UNIT



OM27

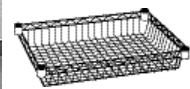

OM28

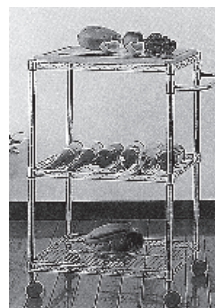

UTILITY CARTS UNIT



UTILITY CART
18"Dx36"Wx33"H
UC2448C

**BUILT-IN
LEVELLER**



OM09

**5"DIA PU CASTERS
STEM TYPE # PU5**



P72C-2 POST

SPVC3 CASTER

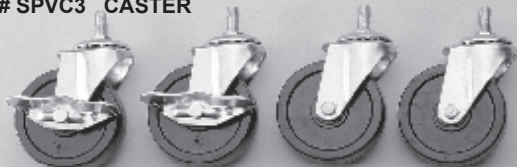

M1-1
(4) P14B
(4) P34B
(8) M1848B
(1) 50"X38"
CHERRY
LAMINATED
MELAMINE
COUNTER TOP

NOTE:
2 COUNTER
TOP TORSOS
ARE NOT
INCLUDED

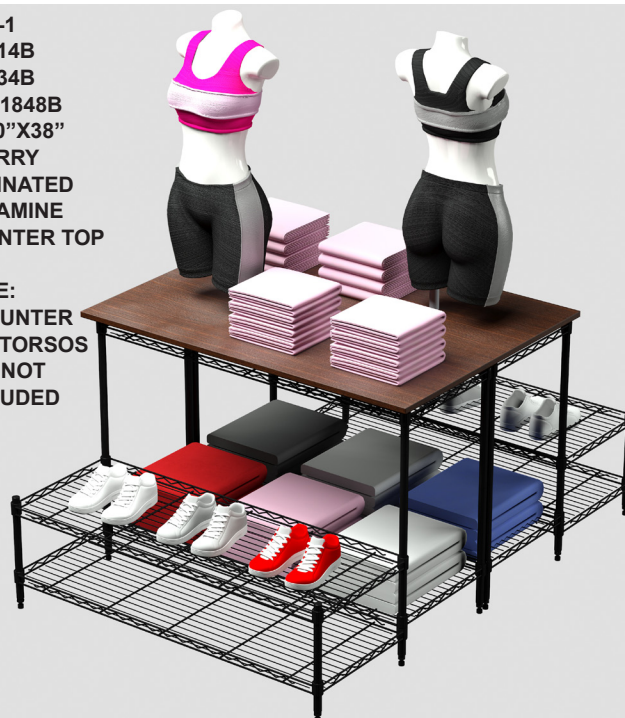

N

OTHER STORE DISPLAY



- (8) Custom 24"X48"X30" Oak laminated storage cabinet.
- (4) Custom 4' modular textured powder coated steel shoe displayer
- (2) Custom 28-1/2" side covers, finish to match shoe displayer

Note: Item # T5-2 on the Left could be an economic alternative. See Chapter T for color and style options.





GS2011 DBJ Booth

This featured center shoe display fixture was modified from Displays By Jack's Global Shop 2011 (GS2011) exhibition booth design. We kept the origami design concept along with one demonstration of possible merchant display but the original booth design's 8' long wings were reduced to 24" in length. The 4 pieces of self standing metal wings are detached from the 8 base cabinets which gives the flexibility for future interior space design.



N OTHER STORE DISPLAY

SHOPPING BASKET



PLASTIC SHOPPING BASKET - RED
HB191410-R



PLASTIC SHOPPING BASKET - BLUE
HB16119-B



WIRE BASKET STAND
WBS

LED OPEN SIGN



NLO-77



NLO-135



NLO-320



NLO-02

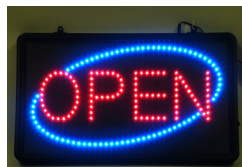

NLO-01 5mm
NLO-01-1 8mm

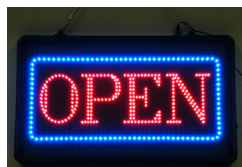

NLO-04

UMBRELLA RACK & PACKING SERIES



FR-040A Silver (40 Holes)
Aluminum & Stainless Steel



FR-025B
Black (25 Holes)
Steel with Black
Painting



FR-025A
Silver (25 Holes)
Aluminum &
Stainless Steel



UMBRELLA PACKING
MACHINE SERIES
SW-M1B

CROWD CONTROL



Addition to our 7 standard colors (black, yellow, red, blue, gray, bronze and gold), we also provide chrome finish and clear pole two options. Clear post can put in beverage can, company's brand, safe sign and various advertising display. 3 types of top heads, 3 types of base, and 10 colors and 2 lengths (200cm and 400cm) for tapes are also available. Various add-on accessories include banner supports and sign holders.



SW-R series
Standard Velvet Rope
colors: red, black and blue.



SHOPPING CART



SXC series

YB-A series



YB-G002



YB-J003

LED MULTI-FUNCTION STAND



08-1S ALUMINUM ALLOY SIGNBOARD

08-1G

U4-1G

08-3G

08-2S

RS-A2SR-RD

TRAFFIC BARRIER

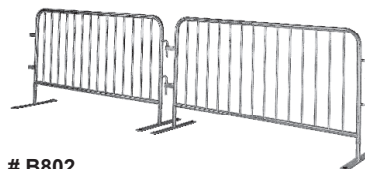

B802

SEATING AREA BARRIER



BANNER SUPPORT # BS-140 & # BS-170



CB-3A

CB-3B

CB-3C

CB-1

CB-2

CB-3

P

PEGBOARD FIXTURE

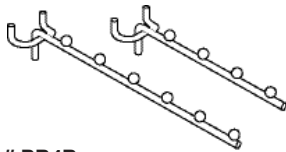

PB4B
PB6B

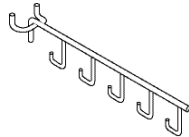

16" LONG WATERFALL
PB5H

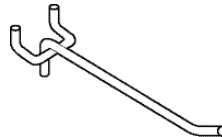

PEGBOARD HOOK WITH
STRAIGHT CUT; PBHS series

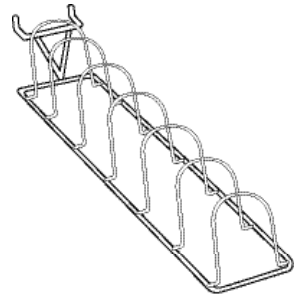

CLUTCH PURSE DISPLAYER
SW-CL

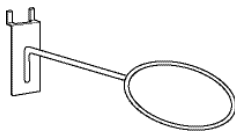

BALL HOLDER
PBB2

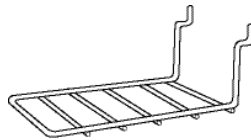

EARRING LADDER DISPLAYER
ELD

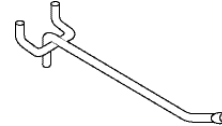

PEGBOARD HOOK WITH
BALL TIP END; PBHB series

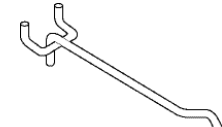

PEGBOARD HOOK WITH
DOWNTURNED; PBHD series



Utilizing our wide range of stock standard items or mix matching our standard parts to get your own unique store display without paying custom design price. Please provide your room size (W X L X H) and items to be displayed, our design department will be able to assist you with economic solutions to fit your budget. You can purchase custom size of metal pegboards by contacting one of our Factory Representatives.

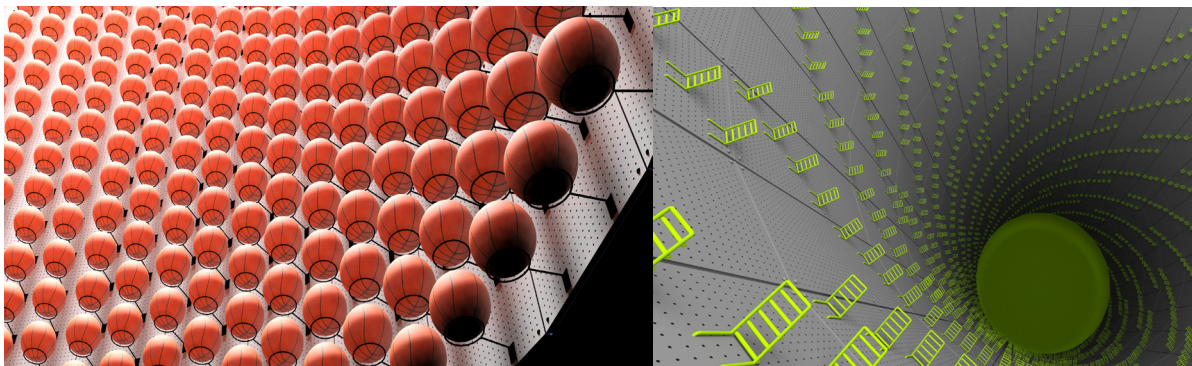

SPORT GOODS SPECIALTY STORE ATRIUM DISPLAY
24" X 48" powder coated metal pegboards with Ball Holders #PBB2 for the left picture and #ELD for the right picture.

R

RACK

BELT & TIE RACKS

RK56



RB56



RK88

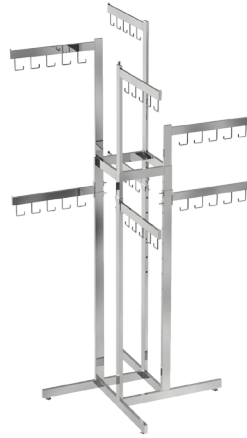

MQ84C-BLACK

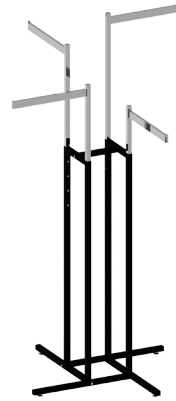

RR22C-BLACK



GARMENT RACKS

R80-2



MQ74C

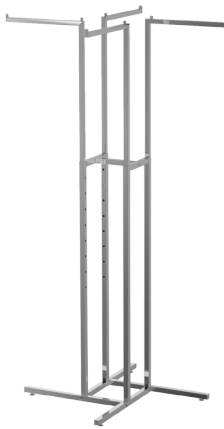

CR42



RCS-1



RK43



SQDA-V

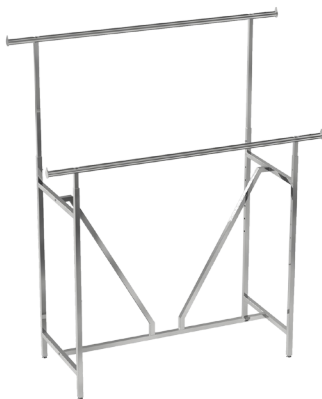

SQDA-Z

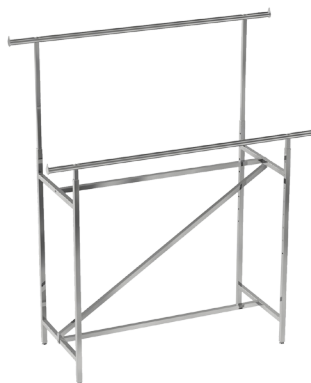

RQDA-C



EZ1





SHOE RACKS

SSJ-RH

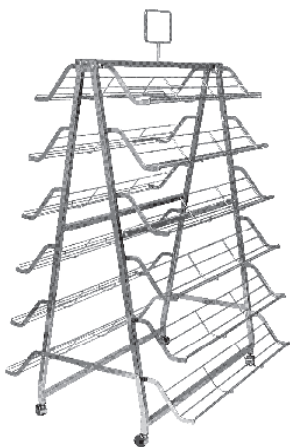

SSJ-110

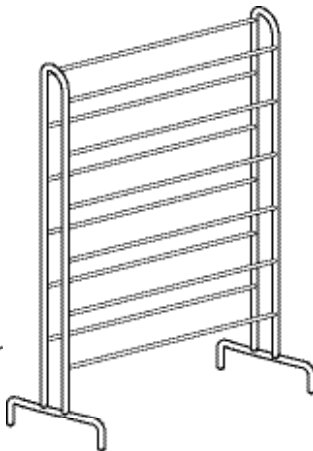

SSJ-120

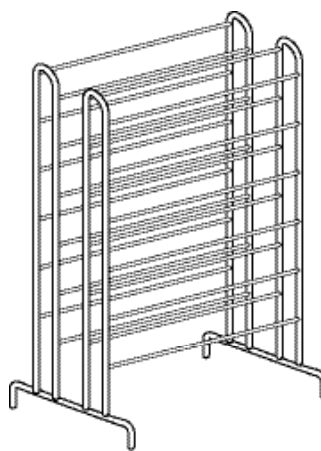

JEWELRY RACK

MULTIPURPOSE RACKS

RK59 & # RR36



RK34-37



R6403F

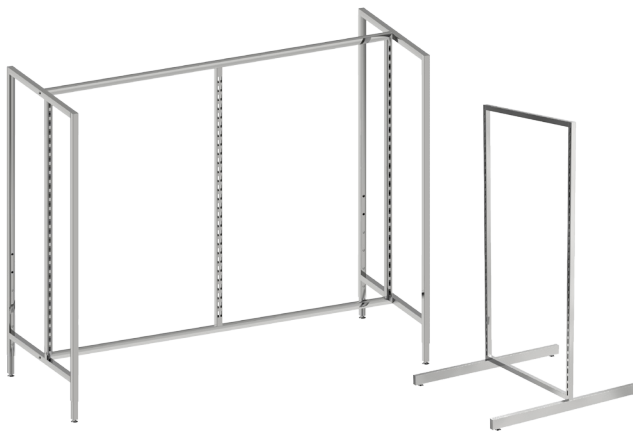

TF156



BAGGING DISPENSER

RK30

RK31

RK32

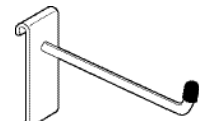

4" Jewelry Hook
Chrome plated
JH4

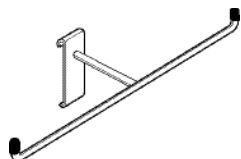

11" Jewelry "T" Hook
Chrome plated
JTH11



VM40 & # R436C

R
RACK

SPINNERS AND COMPONENTS

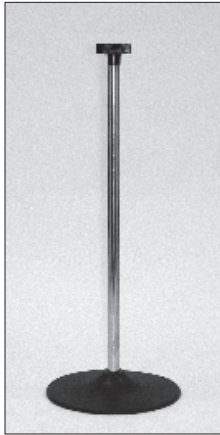

**31" HIGH COUNTER
TOP DISPLAY**
With 12" Dia Black
Durable
Plastic Base
CT

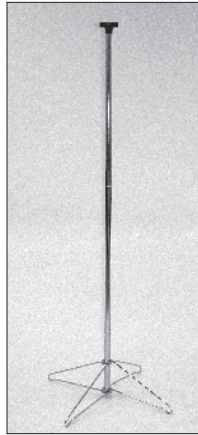

**63" HIGH FLOOR
RACK**
With Wire Base
WB

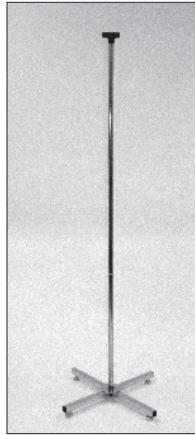

**63" HIGH FLOOR
RACK**
With Tubing Base
TB

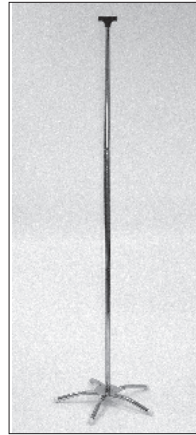

**63" HIGH FLOOR
RACK**
With 5- Claw
Tubing Base
5TB

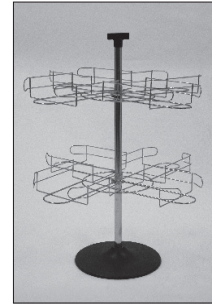

CTCP

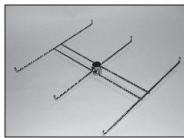

6H



8H

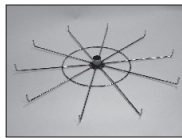

10H



12H

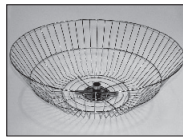

BT



CA

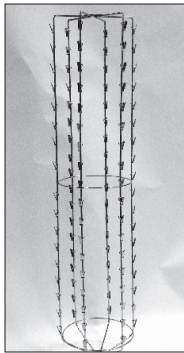

CS

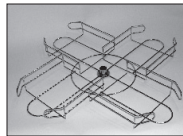

CP

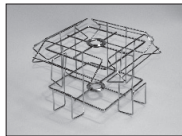

DV

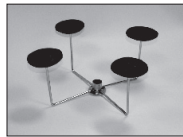

HT

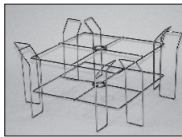

LT

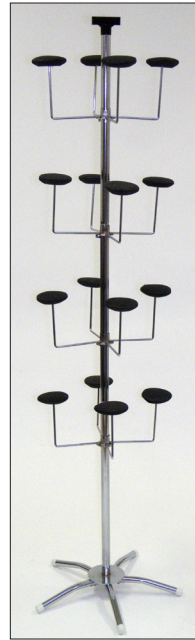

5TBHT



TBBT

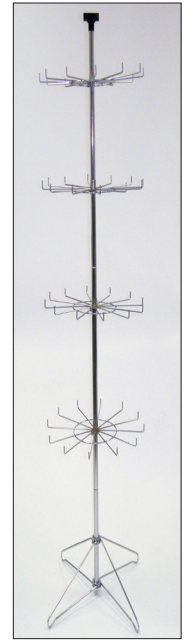

WB12H

Note: # BT & # CS are not available for # CT (Counter Top Display).



J DISPLAYS
By Jack

INSPIRING DISPLAYS

Elegant Simplicity
INSPIRED by NATURE

R
RACK

Please visit us at www.DisplaysByJack.com for more selections.

T

SHOWCASE, COUNTER, TABLE & MIRROR

Durable melamine laminate surfaces come with options of Black, Cherry, Maple, White and Walnut. Multiple sizes are offered for most of showcases, counters, display tables and bases. Showcases and wallcases have 1/4" tempered safety glass with stain finished clear anodized aluminum door frame extrusions and chrome finished standards and brackets.



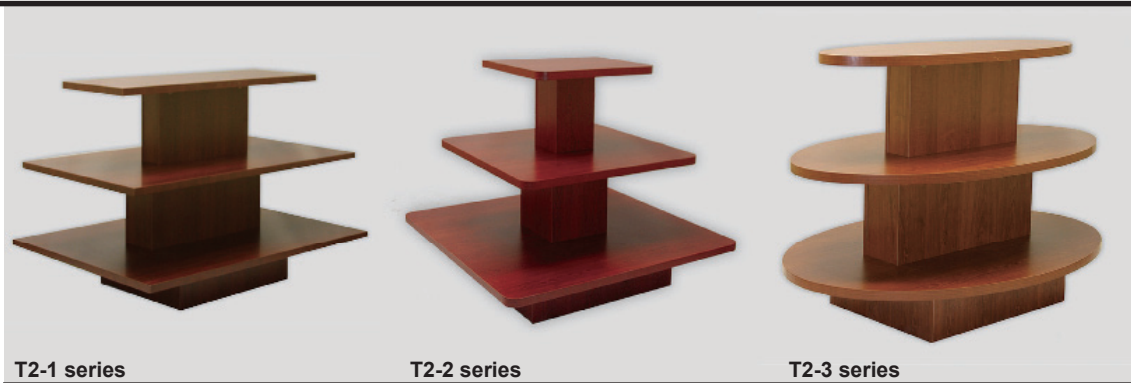

ACRYLIC SIGNHOLDERS

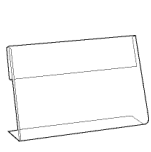

SLANT SELF STANDING
PH series



SLANT BACK SIGN HOLDER
AC-8101

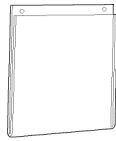

SCREW MOUNT OR HANGING SIGN HOLDER
JD series

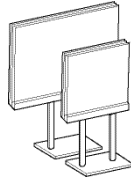

TWIN 4" POST
SAP series

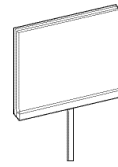

ADD-ON with 3"L Swedge Stem
PJ series

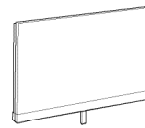

ADD-ON accepts 1/4" or 3/8" stems
SA series

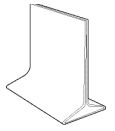

TOP LOADING
TL series

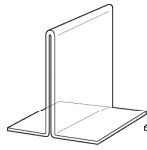

BOTTOM LOADING SIGN HOLDER with 2-sided sign holder
top left 2 items - AC series
bottom right 3 items - PG series

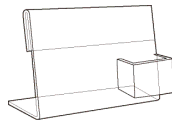
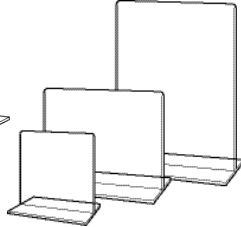
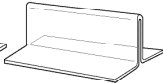

WITH POCKET FOR LITERATURE
AC-1086

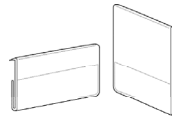

FOR SLATWALL
AC-80 series

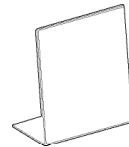

SLANT SELF STANDING
SH1411



SIGN CLIP WITH MOUNTING CLAMP
Clamp fits up to 1-1/4" round, rectangular or square tubing.
WB-48

BULLETIN, EASEL AND ADD-ON



#DBU
22"X28"
DOUBLE BULLETIN SIGN HOLDER
Constructed of 5/8"x1-5/8" Rectangular tubing; 15"X24" base; height 60"



#TBU
22"X28" TRIPLE BULLETIN SIGN HOLDER
Constructed of 1-1/4" square tubing; 24"X25" base; height 90"



BURD28
22"X28" SIGN HOLDER on two 31" round uprights with 10"X14" heavy base; height 59"



BURT28
22"X28" SIGN HOLDER
Vertical frame and base are made of rectangular tubing 1/2"X1 1/2". Base 15"X23 1/2". Height 56"

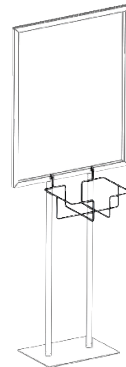

#U2-2
LITERATURE TRAY(Horizontal)
12"W x 4"H x 9"D

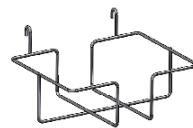

#U2-1
LITERATURE TRAY(Vertical)
9"W x 9"H x 4"D

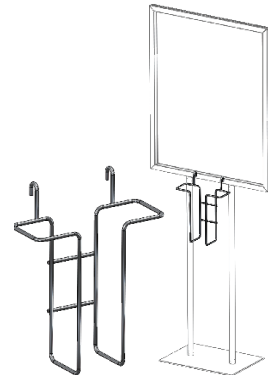



CLAMP & STEM OPTIONS

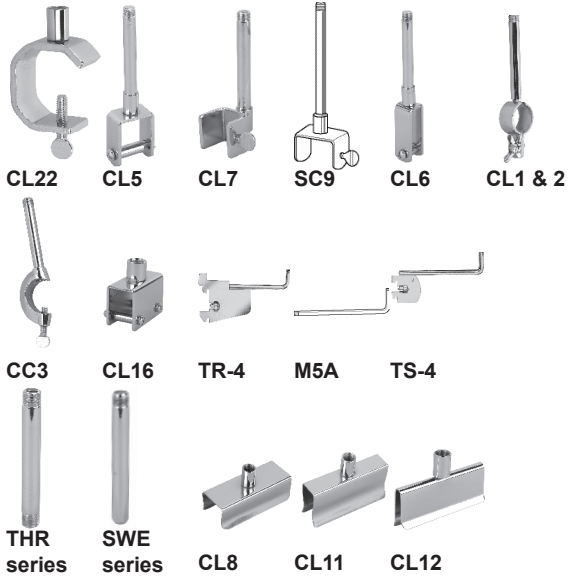

MITRED CORNER OPTIONS



ROUND CORNER OPTIONS

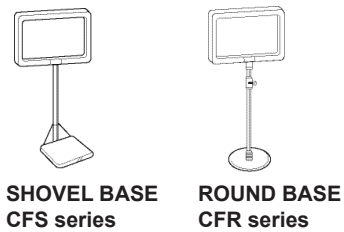

MAGNETIC OPTIONS

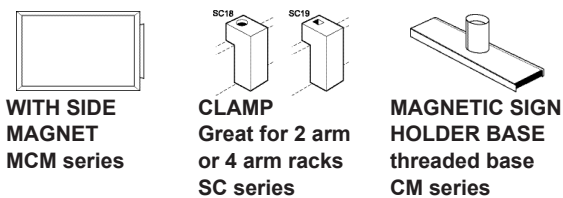

DBJ offers five types of Slatwall Merchandisers. There are 5 selections for the durable melamine laminated surfaces - Black, Cherry, Maple, White and Walnut.



T4-4 series

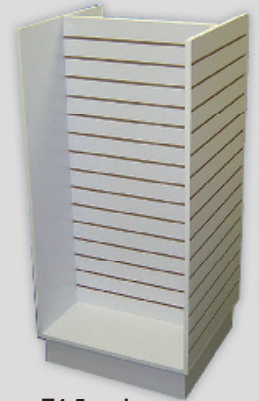

T4-5 series

METAL ACCESSORIES

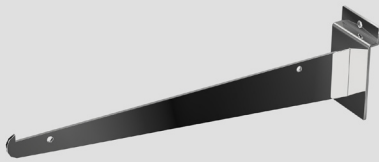

SWKB series

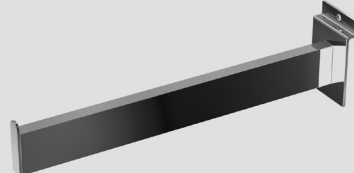

RW series

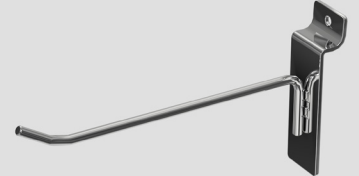

SWH series

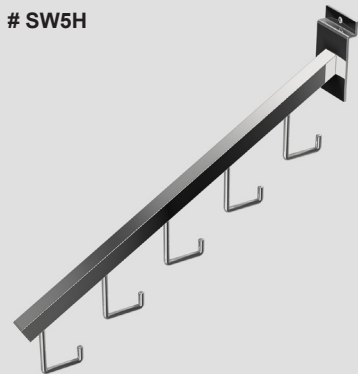

SW5H



SW6B

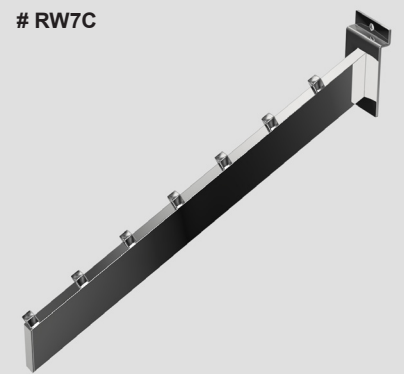

RW7C

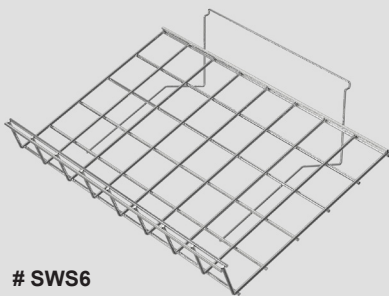

SWS6

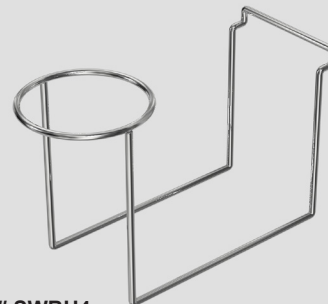

SWBH4

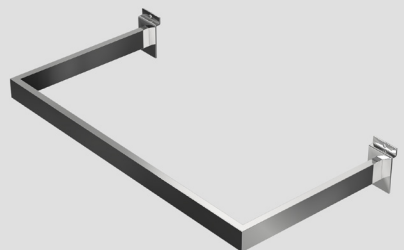

KHS681-RT



T4-3 series



T4-2 series



T4-1 series

SLATWALL PANELS & GROOVE TREATMENTS

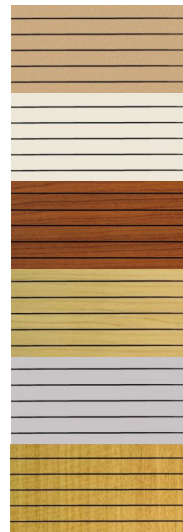

Paint Grade

Swiss Almond Melamine

Cherry Melamine

Alum Rock Maple

Tornado Grey Melamine

Whitter Anigre

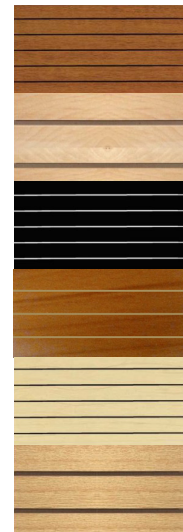

Windor Anigre

White Birch Veneer

Trojan Black Melamine

Pearwood Melamine

Sierra Maple

Fine Oak Melamine



Vinyl (left) and Aluminum (right) Inserts: These inserts add hanging strength to the slatwall panel. Aluminum Inserts add the most strength and are recommended when displaying heavier items. Must purchase our slatwall with these inserts already installed in the groove. They can not be added later.

Color Snaps (left) & Trim Strips (right): Decorative inserts to hide the bare wood groove and do not add hanging strength. Color Snaps & Trim Strips may be purchased separately & added after slatwall is installed.

SPACE SAVER SLACK WALL SYSTEM

HANGRAIL: 1" square chrome tubing. Holes drilled on 1" center to accommodate 12 folded slacks per running foot.
4' Long
R89-4

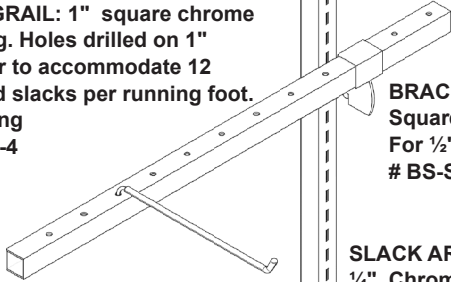

BRACKETS
Square tubing bracket
For 1/2" slots on 1" center.
BS-ST

SLACK ARM 14"L.
1/4" Chrome rod Covered with serrated plastic. Stops slacks from slipping.
R162

NOTE:
ARMS SWIVEL FROM SIDE TO SIDE FOR FULL VIEW OF SLACKS ALLOWING EASY SELECTION BY CUSTOMERS!

BRACKET (BS-ST) CAN ALSO WORK WITH SLOTTED STANDARDS

125 MEDIUM DUTY

ITEM	LENGTH
# 125-3	3'
# 125-4	4'
# 125-5	5'
# 125-6	6'
# 125-7	7'
# 125-8	8'

131 HEAVY DUTY

ITEM	LENGTH
# 131-3	3'
# 131-4	4'
# 131-5	5'
# 131-6	6'
# 131-7	7'
# 131-8	8'



Photo at left contains the following items; white fabrics are for demonstration only

- (3) FIN300
- (6) BS-ST
- (4) R89-4
- (40) R162

Note: The top left 5 hooks shown in different lengths

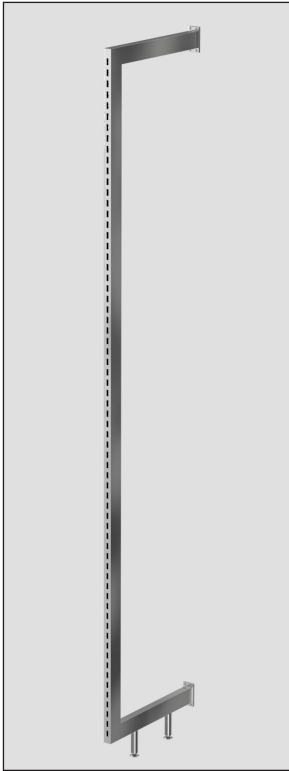

DELUXE OUTRIGGER WALL UNIT

Highly polished 1" x 2" chrome with 1/2" slots on rear. 87" high with 15" from wall.

All welded construction to acquire most sturdiness.

- # RFS50 - Chrome Plated
- # RFS50B - Black Epoxy
- # RFS50W - White Epoxy

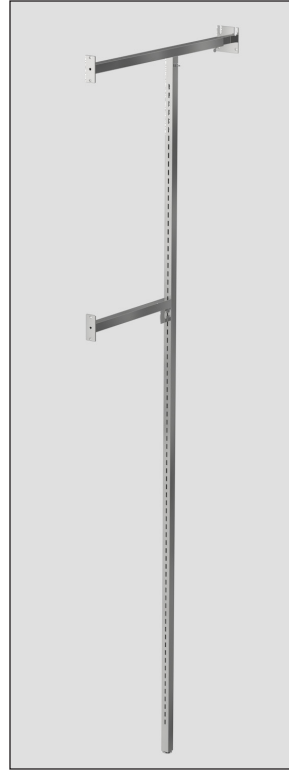

STA300 CORNICE TYPE OUTRIGGER

Constructed of 1" square tubing 84"H. Stands 15" from wall. Top cornice bracket is adjustable from 24" to 36". 1/2" slots in rear for all standards hangrail and shelf brackets. Polished chrome.

- Takes:
- | | |
|--------------|----------------------------------|
| 1 - # LVGC | Leveler |
| 1 - # STA-TB | Top bar |
| 1 - # STA-B | Side Bar |
| 1 - # STA-U | 1" sq. upright slotted one side. |

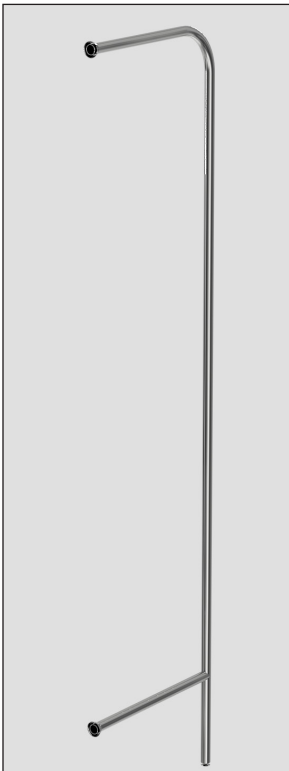

ROUND CHROME FIN
Constructed of round tubing. Stands 24" from wall. 1/2" slots in rear for all standards hangrail and shelf brackets. Chrome finish.

- 1 1/4" Diameter Outrigger
AR501 96" high

- 2" Diameter Outrigger
AT500-1 96" high
AT500-2 108" high

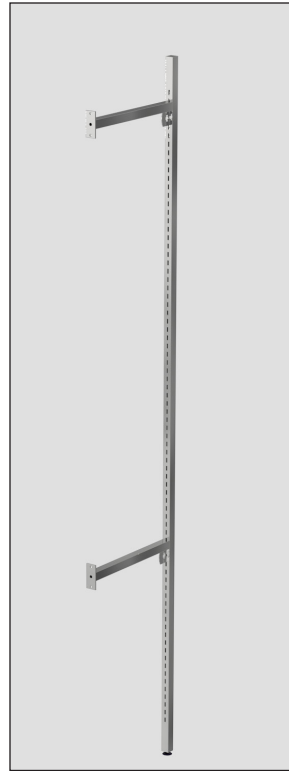

FIN300 FLUSH TOP OUTRIGGER

Same as above, except no cornice arm. Polished chrome.

- Takes:
- | | |
|------------|----------------------------------|
| 1 - #LVGC | Leveler |
| 2 - #FIN-B | Side Bar |
| 1 - #FIN-U | 1" sq. upright slotted one side. |











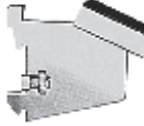

PS. # STA-B = # FIN-B

Z

FACE-OUT & WATERFALL

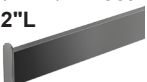





ULTIMATE SELECTIONS WITHIN YOUR BUDGET

Customize your own hooks by mix-matching our typical

<p>Select Face-Out below and match with proper bracket at right</p>	 Wall	 Standards 1/2" Slots 1" On Center	 H/D Standards 1" Slots 2" On Center	 Horizontal 1" Sq Tube	 Horizontal 1/2" x 1 1/2" Rect. Tube	 Vertical 1" SQ Tube
<p>Straight Face Out 3/4" Sq. Tube, 12"L</p> 	TB12	TS12	TR12	TH12		TV12-12" TV16-16"
<p>Waterfall 3/4" Sq. Tube, 18"L, 7 Balls</p> 	BW7B	BS7B	TR7B	BH7B		BV7B
<p>Hook Waterfall 3/4" Sq. Tube, 18"L, 5 Hooks</p> 	HW5H	HS5H	TR5H	HH5H		HV5H
<p>Straight Face Out 1 1/2" x 1/2" Rect. Tube, 12"L</p> 	RB12	RS12	RR12		RH12S	TV12R TV16R
<p>Waterfall 1 1/2" x 1/2" Rect. Tube 17"L, 7 Balls</p> 	RB7B	RS7B	RR7B		RH7B	
<p>Waterfall 1 1/2" x 1/2" Rect Tube 17"L, 8 Cubes</p> 	RB8C	RS8C	RR8C		RH8C	
<p>Hook Waterfall 1 1/2" x 1/2" Rect Tube 17"L, 5 Hooks</p> 	RB5H	RS5H	RR5H		RH5H	



brackets with our standard Face-out or Waterfall options.

 Vertical 5/8" x 1 5/8" Rect. Tube	 1" x 3/16" Crossbar	 " J " Rail	 Slatwall	 Gridwall	
	WR12-12" WR16-16"		SW12	GW12	
	WR7B	TJ7B	SW6B 16" 6 balls	GW7B	
	WR5H	TJ5H	SW5H 16" 5 hooks	GW5H	
RV16-16" RV22-22"			RW12	RG12	
			RW7B	RG7B	
			RW7C 15" 7 cubes	RG8C	
			RW5H	RG5H	

Z FACE-OUT & WATERFALL

CUSTOMER SERVICE

At Displays By Jack, we have earned our reputation of excellence in customer service. All of the elements of our company come together to provide the customer with the best product for the best value. We realize the importance of all orders from multi store rollouts to fill-in orders. We know that the customer has trusted us to fulfill their needs and all resources are utilized to insure customer satisfaction. Customer service has evolved into Customer care. We are not just processing orders, we are developing long term relationships.





QUALITY CONTROL AND QUALITY ASSURANCE

Pride comes from our people and Pride shows in our products. Our quality control department oversees all fulfillment work, coordinates supplies, storage, and drop shipping for a seamless, Just-In-Time process. We pay extra attention to each detail from raw material, product fabrication, testing, packaging and distribution. It is through our continuous effort that our customers get the consistently high quality products they have come to expect.





Custom items will be priced according to quantity, material, finish and destination. Contact our factory representatives for quantity pricing and your custom design items.



CUSTOM DESIGN

Our sales force and designers work with you to conceptualize your vision keeping your chain store brand identity in mind. Whether your needs are for a single function fixture or complete line of merchandising hardware, our team is ready and able to offer support. Providing custom design solutions that are unique and exclusive while maintaining your budget are the criteria we use. Utilizing our computer modeling software and hand sketches, our team can bring your project to life so you may see it prior to commissioning a prototype. A network of world-wide partners allows us the ability to offer our customers a large selection of design options and a wide array of material choices such as metal, wood, acrylic, recycled paper, fabric and much more. We also have the ability to fabricate mannequins to match the models from your seasonal marketing material.

CUSTOM DESIGN

MANUFACTURING AND WORKMANSHIP

Displays by Jack has been a manufacturer for the past 33 years, in that time we have become one of the leaders in supplying quality products. Many of the management staff have been with the company since its inception. This assures the client that the consistency of our products is maintained to the highest standard set from the beginning. Our association with our other partners gives you, the client, endless possibilities. Our customers receive the personal attention to insure our standards are maintained throughout the project. A complete array of finishes are available, such as chrome, dull nickel, zinc, and bronze plating. These finishes may also be polished, satined, and textured. Other options available are anodizing, power coating or custom graphic.

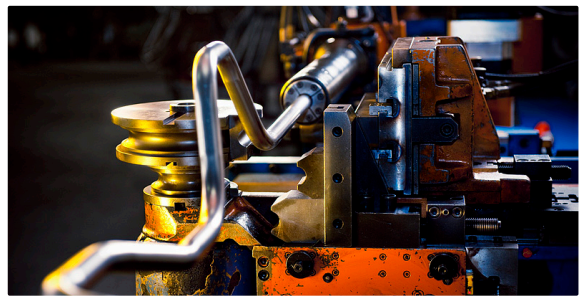
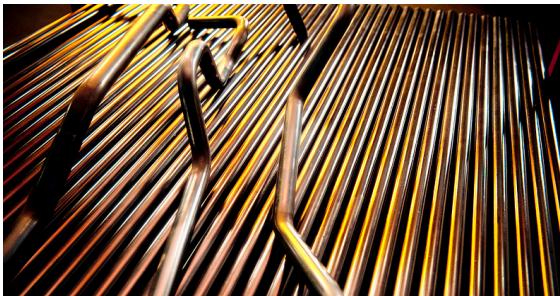



MANUFACTURING AND WORKMANSHIP

Please visit us at **www.DisplaysByJack.com** for more selections.

WAREHOUSING & DISTRIBUTION

Our new 74,000 square foot warehouse enables us to inventory numerous standard items that are most common in the industry. This gives our customer a reliable source to quickly fill their needs. DBJ also has a blanket order and distribution system which allows for planned multi store openings and rollout programs. Inventory can be released and tracked so that all due dates can be met. We ship anywhere in the US, Canada or Mexico by the customers specified carriers or make arrangements using any of the Freight Companies that we have negotiated rates with.





WAREHOUSING & DISTRIBUTION

Please visit us at www.DisplaysByJack.com for more selections.

PAYMENT AND FINANCING

Terms

- **Credit Application Form (Authorized signature is required for Bank reference.)**
- **Three (3) U.S. based trade references with comparable terms.**
- **Term: Net 30 days with approved Credit Line with Displays By Jack.**

Payment Options

- **Payment by Direct Wire (T/T)**
- **Payment by Check**
Payable to: Displays By Jack
Out of state check is a required 5-7 business day to be cleared.
- **Payment by Credit Card**
VISA & Master Card only
Signature on Credit Card Authorization Form is required.

Pricing

- **Prices are subject to change without further notice.**
- **Shipping/Freight charges will be quoted accordingly.**
- **All California Order are subject to the state sales and use taxes, unless valid CA resale certificate is provided.**
- **Special Quantity order or Custom/Unique order will be quoted with special terms separately.**
- **We reserve the right to correct typographical errors.**

Return Policy

Non-Stock, custom / special orders are not eligible for return. Claims for concealed damage goods or shortages must be on receipt at the time of delivery within five (5) days of receipt of goods.

Merchandise should be returned within 30 days of the invoice, upon approval.

Items must be returned in the original packing and must be new and resalable.

Returns are subject to a 20% restocking fee and at customer's expense.

Refund will be provided with approval by RMA department.

Displays By Jack reserves the right to accept or refuse returned merchandises.

All returns must be addressed to: Displays By Jack

12930-12950 Alondra Boulevard,

Cerritos, CA 90703, U.S.A.

Tel: (562) 802-0888 or Toll Free: (855) DBJ-DISP







Where Fixtures Live

First Published in the U.S.A in 2012

by **Displays By Jack**

All rights reserved. No part of this publication may be reproduced, stored in a retrieval system, or transmitted in any form or by any means, electronic, mechanical, photocopying, recording, or otherwise, without prior consent of the publishers.

Printed in Taiwan

Edited date: November 2, 2011

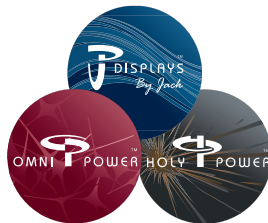

Performance Beyond Expectation

Displays By Jack (DBJ) is an authorized distributor for Omni-Power CO., LTD., (OP) and Holy-Power Industries CO., LTD. (HP). DBJ, OP and HP are separately and independently operated companies.